

Gigant + Orangerie

Produktinformatie

Geachte klant,

U heeft met de aanschaf van de GIGANT aluminium serre een juiste keuze gemaakt waarmee wij u veel plezier wensen.

Opmerkingen

Deze handleiding is vooreerst opgesteld voor alle standaardconstructies maar bevat voldoende aanwijzingen om een vlotte montage van andere uitvoeringen te garanderen. De zwarte rubber strips zijn aan de binnenkant met olie behandeld. Dit garandeert een eenvoudige en snelle montage. Bovenaan het gootprofiel is een inbrengdetail voorzien maar hier dient GEEN rubber gemonteerd te worden. Mogelijke zwarte plekken op de profielen zijn eenvoudig met een aluminiumreinigingsmiddel af te nemen, het betreft geen productiefouten. Voor het plaatsen van een fundering in beton, dient de grond vorstvrij te zijn. Het dak van de serre moet in de winter van sneeuw bevrijd worden, of op een gepaste manier ondersteund worden. De serre moet op een van de wind afgeschermd plaats opgebouwd worden. Tijdens de montage dient men gepaste beschermende kledij te dragen (b.v. veiligheidshandschoenen) om kwetsuren te vermijden. Men dient steeds de lokaal gebruikelijke bouwverordeningen in acht te nemen.

Volgorde van de montage

Opbouw en montage volgorde is voor alle GIGANTmodellen hetzelfde.

- Uitsorteren van aluminium profielen volgens modelgrootte.
- Montage en opbouw van gehele constructie
- Horizontaal en waterpas stellen van de constructie.
- Beglazing

Benodigd gereedschap

Schroefsleutel Nr. 10, schroevendraaier, waterpas, boorapparaat en boortje Ø4.2, metaalzaag, werkhandschoenen, schaar (voor het snijden van rubber).

Konstruktiewijzigingen onder voorbehoud.

Product Information

Dear customer,

Thank you for buying a high-quality aluminium greenhouse model GIGANT.

Remarks

In all drawings you find the mounting-instructions for all basic standard-models. However this manual should be a sufficient guidance for all special-case greenhouses. The aluminium profiles may show black stains, these stains are not a production error. They can be easily removed with a aluminium cleaner available at every good drugstore. The rubber profiles have been treated with oil on the interior to facilitate the assembly. The ground must be frost-free in order to place a concrete foundation. During winter the roof has to be cleared of snow or supported in a suitable way. The greenhouse should be built in a location protected from strong winds. Protective gear (such as protective gloves) should be used during construction in order to avoid injuries. One should at all times pay attention to the local building regulations.

Assembly order

The assembly procedure is the same for all GIGANTgreenhouses.

- Sorting of the profiles according the model.
- Mounting of the complete aluminium construction.
- Levelling of the construction using a water-level.
- Glazing.

Required tools

Socket wrench nr. 10 or spanner nr. 10, water-level, screwdriver, drilling machine + drill 4.2 mm, scissors (to cut the rubber)

We reserve the right to change the construction without prior notice!

Information sur le produit

Cher client,

Nous vous félicitons à l'achat de la serre en aluminium, modèle GIGANT.

Remarques

Dans ce manuel vous trouvez les instructions de montage pour tous les modèles standards d' Arcadia. Par contre, ce manuel est aussi un bon guide pour tous les modèles spéciaux. Les couvercles noirs en caoutchouc sont, à l'intérieur, traités à l'huile. Ceci garantit un montage simple et rapide. Si les profilés en alu montrent des taches noires, il ne s'agit pas d'un défaut de production. Ces taches peuvent facilement être enlevées au moyen de nettoyeurs pour aluminium, qui sont disponible sur le marché. Le coulage d'une fondation en béton ne peut pas être mis à exécution quand il gèle. Pendant l'hiver il faut enlever la neige de la toiture ou étançonner le toit. Il faut construire la serre dans un endroit protégé du vent. Afin d'éviter des blessures lors de la montage, il faut porter des vêtements de travail, qui pourront vous protéger (p.e. des gants de sécurité) On doit de tout temps respecter les règles urbanistiques locales.

Déroulement du montage

L'ordre de montage est identique pour tous les modèles GIGANT:

- Triage des profilés en alu en fonction des dimensions du modèle.
- Assemblage des profilés et montage de la structure.
- Alignement vertical et horizontal de la construction.
- Pose du vitrage.

Outillage nécessaire

Clef N° 10, tournevis, niveau à bulle, perceuse et foret Ø4.2mm, scie à métaux, gants de travail, ciseaux (pour la mise à longueur du joint en caoutchouc).

Sous réserve de tout changement.

Produkt Information

Sehr geehrter Kunde,

Wir möchten Ihnen zum Kauf des Gewächshauses Modell GIGANT gratulieren.

Bemerkungen

Die Aufbauanleitung bezieht sich zunächst auf das Standardmodell „Arcadia“. Für die Sonderkonstruktionen gibt es zusätzliche Hinweise zur Montage. Das Gewächshaus soll in einer windgeschützten Lage montiert werden. Im Winter muss das Dach von Schnee befreit oder durch geeignete Maßnahmen abgestützt werden. Alle Konstruktionen sind nach baurechtlichen Vorschriften am Boden zu befestigen. Unlackierte Alu-Profile können schwarze Flecken aufweisen. Hierbei handelt es sich nicht um einen Produktionsfehler. Durch handelsüblichen Alu-Reiniger lassen sich diese entfernen. Das mitgelieferte Dichtungsgummi ist an der Innenseite mit Talg behandelt, was zu einer schnelleren und einfacheren Montage beiträgt. Bei der Montage muss man Schutzausrüstung tragen z.B. Sicherheitshandschuhe, um Verletzungen zu vermeiden.

Montageablauf

Der Montagevorgang ist bei allen GIGANT-Modellen gleich:

- Auslegen der Alu-Profile gemäß Modellgröße.
- Aufbau der Alu-Konstruktion.
- Horizontale und vertikale Ausrichtung der Konstruktion.
- Verglasung.

Benötigtes Werkzeug

Schraubenschlüssel Nr. 10, Schraubenzieher, Wasserwaage, Bohrmaschine und Bohrer (4.2 mm) Metallsäge, Schere (für das zuschneiden der Gummidichtung).

Konstruktionänderungen sind behalten wir uns vor.

Produkt-information

Kære kunde,

Tillykke med Deres nye GIGANTdrivhus. De har valgt et højt kvalitetsprodukt, som De vil få megen fornøjelse af.

Bemærkninger:

Denne montage-vejledning er først og fremmest lavet for alle vores standardkonstruktioner, men kan også bruges til montage af specielkonstruktioner, da der er inkluderet flere supplerende anvisninger. Alle gummilister er indvendigt behandlet med olie, som sikrer en enkelt og hurtigt montage. (Pas på det kan smitte af på fliserne) .På underkanten af tagrenden er der forudset en rille, hvor der IKKE skal monteres gummilister.

Mulige sorte pletter på profilerne kan nemt fjernes med et aluminiums rengøringsmiddel – disse er ikke produktionsfejl.

Hvis De laver et fundament i beton, skal undergrunden være frostfrit.

Taget skal om vinteren så vidt muligt gøres frit for sne.

Fremgangsmåden for montagen:

Opbygning og montage er den samme for alle GIGANT størrelser.

- Lægge alle dele frem
- Monter hele aluminiumskonstruktionen
- Sæt konstruktionen i vatter og i vinkel.
- Monter glasset

Værktøj:

Nøgle nr. 10, skruetrækker, vatterpas, boremaskine og bor Ø 4,2 mm, arbejdshandsker, saks (for at klippe gummilisterne)

Vi tar forbehold om endringer i konstruksjonen.

Produktinformasjon

Kjære kunde

Til lykke med Deres nye GIGANTdrivhus. De har valgt ett høy-kvalitetsprodukt, som vi håper De vil få meget glede av.

Bemerkninger

Denne monteringsveiledningen er først og fremst laget for alle våre standardkonstruksjoner, men kan også brukes til montering av spesialkonstruksjoner, da det er inkludert flere supplerende anvisninger.

Alle gummilistene er innvendig behandlet med olje, som sikrer en enkel og hurtig montering. (Vær obs på at oljen kan smitte av.) På underkanten av takrennen er det en rille hvor det IKKE skal monteres gummilister.

Mulige sorte pletter på profilene kan lett fjernes med ett aluminiums rengjøringsmiddel – disse er ikke produksjonsfeil.

Hvis De lager ett fundament i betong skal jorda/grunnen være frostfri.

Om vinteren bør taket gjøres fritt for snø.

Drivhuset bør plasseres på et lunt sted.

De bør bruke beskyttende tøy som for eksempel hansker ved montering.

Fremgangsmåte ved montering

Oppbygging og montering er den samme for alle GIGANT størrelser.

- Legg alle deler frem.
- Monter hele aluminiumskonstruksjonen
- Sett konstruksjonen i vater og vinkel.
- Monter glassene / isolerplastplatene.

Verktøy

Nøkkel nr. 10, skrutrekker, vater, boremaskin og bor Ø 4,2mm, metallsag, arbeidshansker, saks (for å klippe gummilistene).

Vi tar forbehold om endringer i konstruksjonen.

Produktinformation för montage av GIGANTväxthus

Bästa kund.

Tack för att Ni köpt ett GIGANTväxthus av aluminium med hög kvalitet.

På de följande sidorna hittar ni monteringsanvisningar för de varierande Arcadia modellerna samt skisser på de olika profilerna.

För de hus som inte är lackerade (ren aluminium) kan det ibland finnas mörkare fläckar vilket är naturligt. Dessa kan med lätthet tvättas bort med en aluminiumrengörare som kan köpas i färghandeln.

Gummiprofilerna har blivit behandlade med olja för att underlätta vid montering. Grundarbetet måste vara utfört på sådant sätt att marken inte rör sig vid tjäle samt att huset bör vara förankrat genom fastgjutning.

Vid snöfall under vintern bör snön tas ned från taket. Vid rikligt snöfall bör huset gärna stöttas i mitten på nocken speciellt om Ni inte befinner Er på plats där under vinterhalvåret. Växthuset bör placeras på en skyddad del av trädgården där vinden är mindre stark. Vid montering av glaset bör handskar användas för att skydda mot skärskador. Följ de lokala lagar vad gäller bygglov.

Monteringsföljd

Monteringsföljden är den samma för alla GIGANTväxthusen.

- Sortera upp profilerna och placera dem i den ordning som de skall monteras.
- Montera ihop hela aluminiumkonstruktionen innan glasning.
- Kryssmät diagonalerna noggrant samt använd ett vattenpass innan glasningen.
- Glasning.

Verktyg Som behövs vid montering

Fast nyckel nr. 10 eller hylsnyckel nr. 10.
Vattenpass.

Skruvmejsel.

Sax (för klippning av gummilist).

Borrmaskin och borr 4.2 mm samt 6.5 mm.

Vi förbehåller oss för rätten att ändra i konstruktionen utan att i förväg meddela sådant.

Informazioni generali sul Prodotto

Caro Cliente,

Ti ringraziamo per aver scelto una Serra in alluminio modello GIGANTdi "alta-qualità".

Osservazioni

Nei disegni sono specificate le istruzioni di montaggio per tutti i modelli standard.

In ogni caso questo manuale risulta essere una guida più che sufficiente anche per l'installazione di Serre realizzate "su misura". I profili d'alluminio potrebbero presentare alcune macchie scure. Tali macchie non sono dovute ad errori di produzione e possono altresì essere rimosse usando comuni prodotti

per la pulizia dell'alluminio, disponibili nelle migliori rivendite specializzate.

Le guarnizioni in gomma sono trattate con olii speciali al fine di facilitarne l'applicazione.

Il terreno sul quale viene posata la serra deve essere opportunamente isolato e predisposto per la realizzazione di una fondamenta in cemento.

In inverno, è consigliabile rimuovere la neve dal tetto o supportare la Serra dall'interno. Consigliamo inoltre di installare la Serra in una zona riparata dal vento.

Durante la fase di installazione è preferibile usare dispositivi ed attrezzatura di protezione personale (es.: guanti) allo scopo di evitare qualsiasi danno alle persone.

Consigliamo vivamente di verificare le normative locali vigenti in merito alla realizzazione di strutture di questa tipologia.

Fasi di montaggio











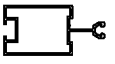

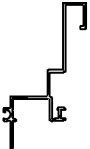

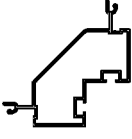



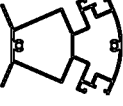

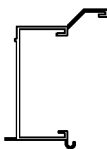

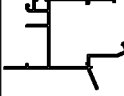

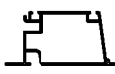
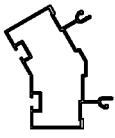

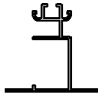

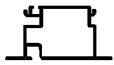

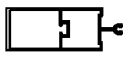

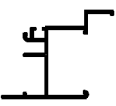
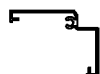

La procedura di installazione è uguale per tutte le Serre modello GIGANT.

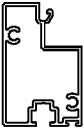
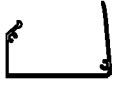
- Verificare e disporre in ordine tutti I profili in alluminio che compongono la Serra.
- Montare completamente la struttura in alluminio.
- Livellare la struttura e controllarne lo squadra degli angoli e delle diagonali.
- Posizionare le lastre di tamponamento (vetro, policarbonato etc.).

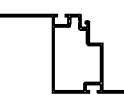

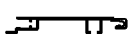



Attrezzatura necessaria per il montaggio

Chiave inglese o chiave a bussola nr.10, livella ad acqua (bolla), cacciavite, trapano con punta ø4 mm, forbici (per tagliare la guarnizione).

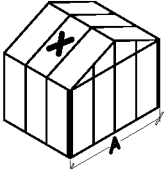
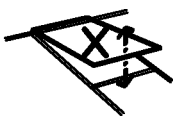

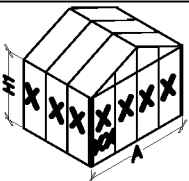
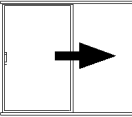

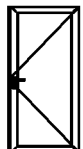
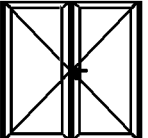

Ci riserviamo il diritto di apportare eventuali modifiche del prodotto in qualsiasi momento e senza preavviso.

PRO29910 Glaslat		PRO6120 Fundering		PRO36689 Gootscharnier		PRO1450 Scharnier var.hoek		PRO744 Buisje dia19	
PRO29911 Hoekstijl		PRO7615 Scharnier dakraam		PRO33329 Scharnier nok		PRO37359 Schap/zaai bak gor/djnkast		PRO10980 Buisje dia40	
PRO29904 Nok helios		PRO19371 Klips dubbelkap		PRO29973 Prof. schermdoek		PRO1458 Goot carrousel		PRO14609 Afsuiter dakraam	
PRO29905 Goot Helios		PRO7610 Onderkant dakraam		PRO1451 Gootdrager		PRO7926 Hoek 150gr.		PRO210 L 40x40	
PRO29906 Tussenregel		PRO7609 Zijkant dakraam		PRO7621 Glashouder		PRO1454 Tussenregel		PRO533 L 20x40	
PRO7614 Deurgelider		PRO33325 Daklat Arcadia		PRO28441 D128		PRO1455 Geleider schuifraam		PRO25827 Kader schuifraam	
PRO6121 Deurkader hor.		PRO33328 Goot Arcadia		PRO39128 Mouluure-houder		PRO1456 Glaslat carrousel		PRO39796 Geleider schuifdeur	
PRO29909 Deurstijl		PRO33326 Muurnok Arcadia		PRO1449 Glaslat var.hoek		PRO1457 Deurkader carrousel		PRO37358 Fundering op muurtjes	
T40x40 T-profiel deur		PRO7614 Opzetprofiel		PRO2290 Zware rubber PPL		PRO5538 Halve rubber Helios		PRO1748 Rubber serres	

GLASS-SIZES: HELIOS & ORANGERIE

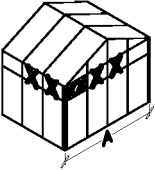
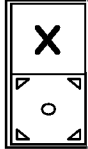
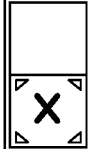
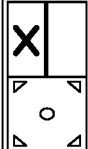
	HELIOS	ORANGERIE
	A=236cm: 730 x 1.250 A=310cm: 730 x 1.650 A=384cm: 730 x 2.000	A=310cm: 730 x 1.710 A=384cm: 730 x 2.032
	730 x 825	730 x 825
	A=236cm: 730 x 425 A=310cm: 730 x 825 A=384cm: 730 x 1.175	A=310cm: 730 x 905 A=384cm: 730 x 1.215
	H1=181cm: 730 x 1.650 H1=201cm: 730 x 1.850	730 x 1.850 Carr. \emptyset 378cm: 905 x 1.850 !! Orangerie A=378!! xx = 698 x 1.850 !
	H1=181cm: 730 x 1.650 H1=201cm: 730 x 1.850	730 x 1.850
	H1=181cm: 710 x 1.650 H1=201cm: 710 x 1.850	710 x 1.850
	572 x 1.700	572 x 1.700 Carr. \emptyset 378cm: 747 x 1.700
	572 x 1.700	572 x 1.700 Carr. \emptyset 378cm: 747 x 1.700
	550 x 865	550 x 865 Carr. \emptyset 378cm: 725 x 865
	730 x 825	730 x 825 Carr. \emptyset 378cm: 905 x 825

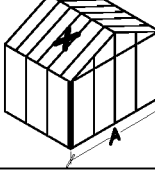
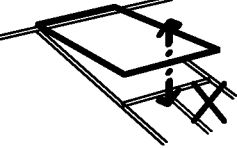
GLASS-SIZES: HELIOS & ORANGERIE

	HELIOS	ORANGERIE
	-	685 x 968 Carr.Ø378cm: 860 x 968
	-	730 x 825 Carr.Ø378cm: 905 x 825
	-	730 x 825 !! Orangerie A=378!! xx = 698 x 825 !
	730 x 1.015	730 x 1.015
	730 x 825	730 x 825
	361 x 1.015	361 x 1.015
	361 x 1.850	361 x 1.850
	A=236cm: 361 x 1.250 A=310cm: 361 x 1.650 A=384cm: 361 x 2.000	A=310cm: 361 x 1.710 A=384cm: 361 x 2.032
	A=236cm: 361 x 425 A=310cm: 361 x 825 A=384cm: 361 x 1.175	A=310cm: 361 x 905 A=384cm: 361 x 1.215
	730 x 825	730 x 825 Carr.Ø378cm: 905 x 825

GLASS-SIZES HELIOS

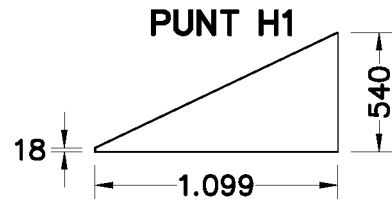
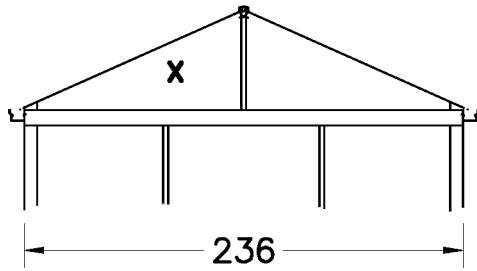

GLASS-SIZES HELIOS & ORANGERIE

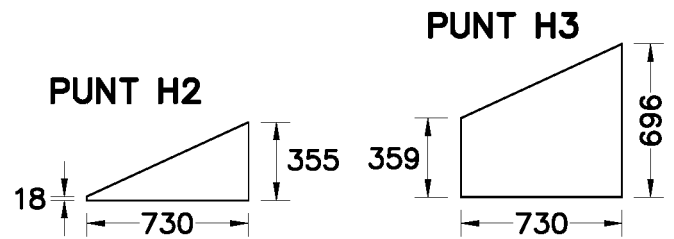
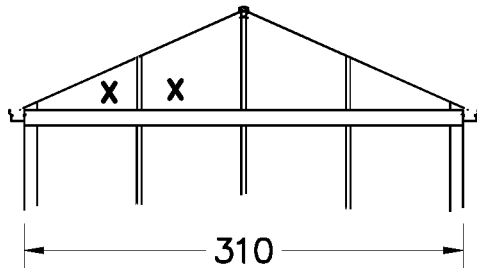

GLASS-SIZES HELIOS

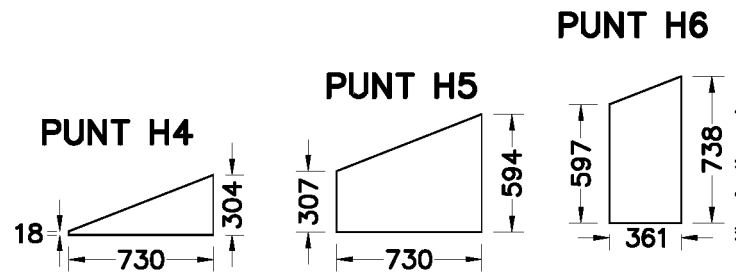
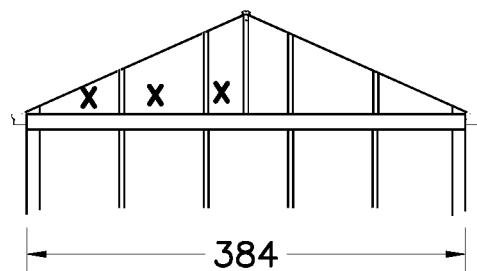

GLASS-SIZES ORANGERIE

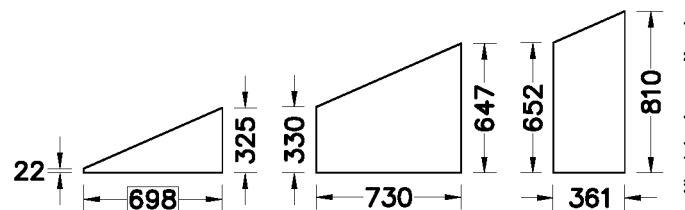
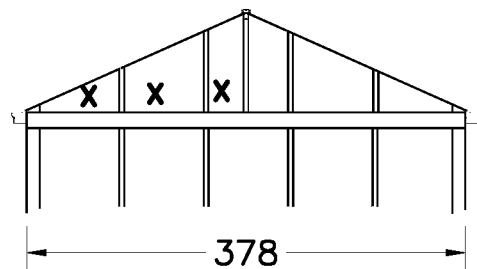

Alle tekeningen zijn steeds buitenaanzicht - Alle afmetingen in mm.

GLASS-SIZES 37-MODULE

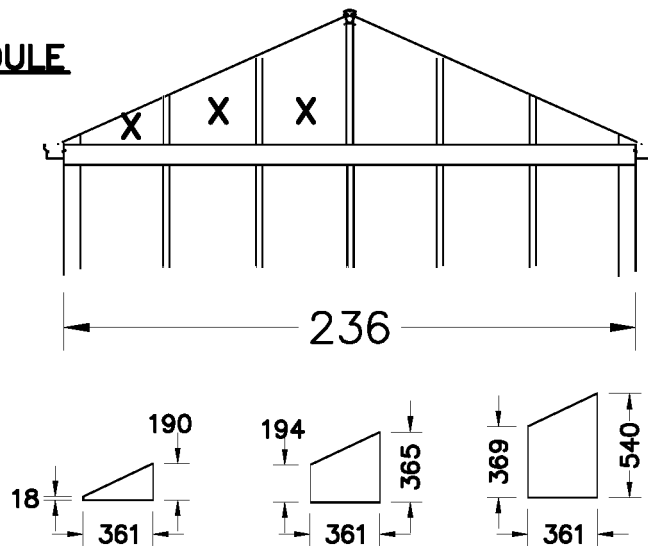

GLASS-SIZES 37-MODULE

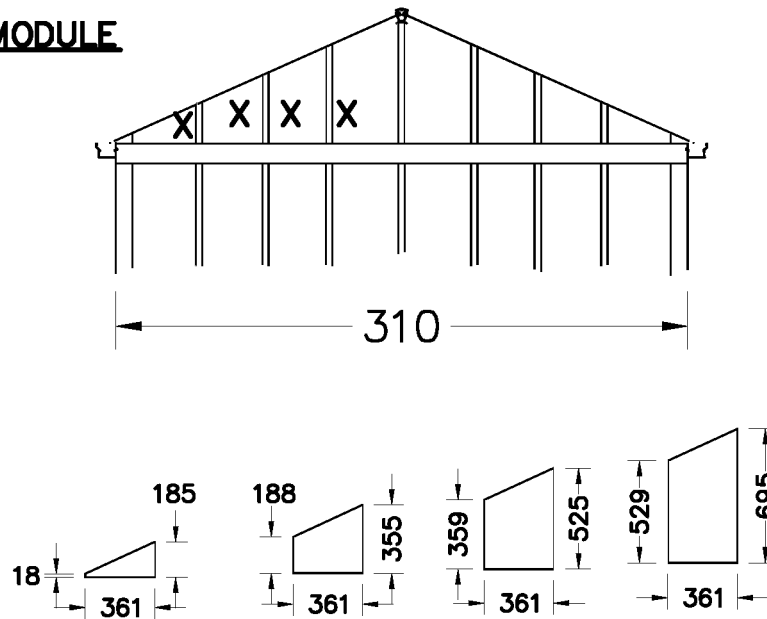

GLASS-SIZES 37-MODULE

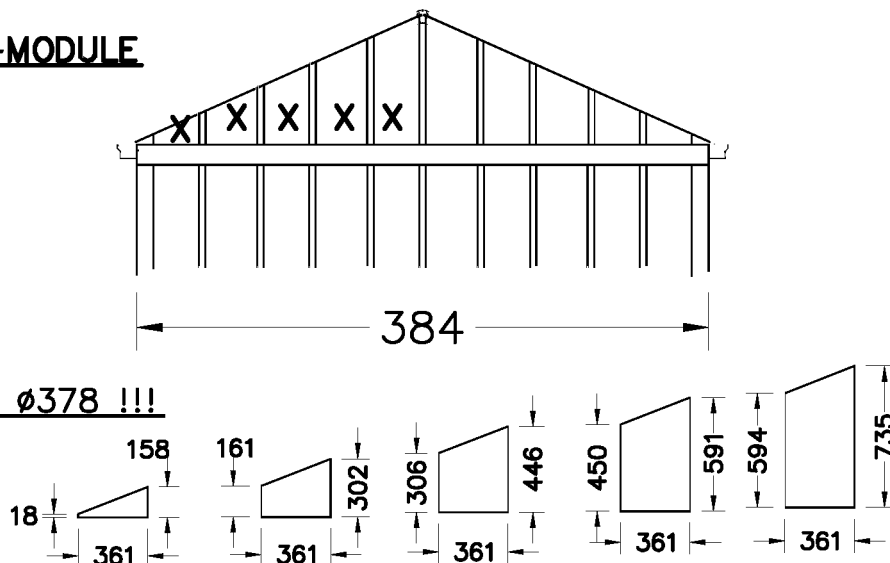

!!! NOT Orangerie ø378 !!!

GLASS-SIZES ORANGERIE 310

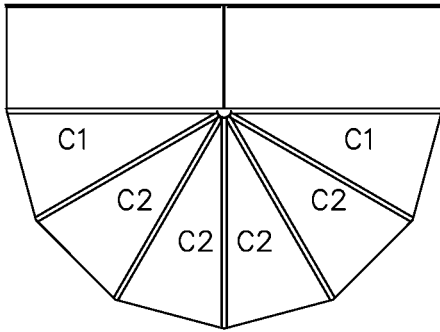

PUNT C2

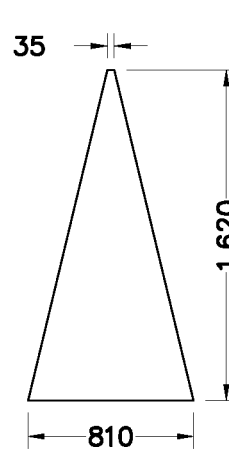

PUNT C1

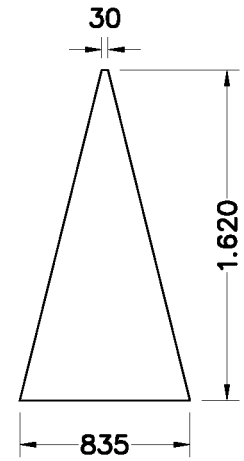

GLASS-SIZES ORANGERIE 378

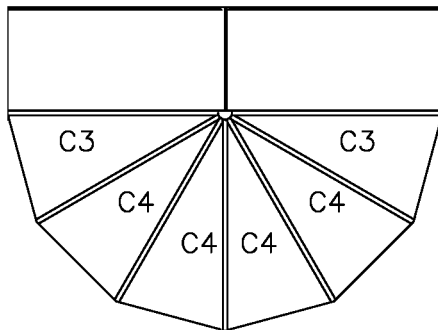

PUNT C4

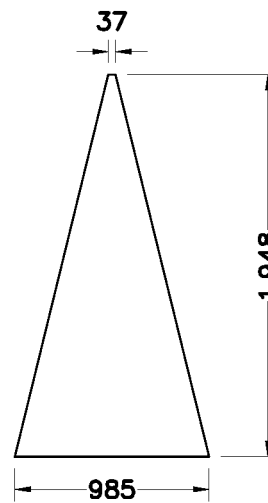

PUNT C3

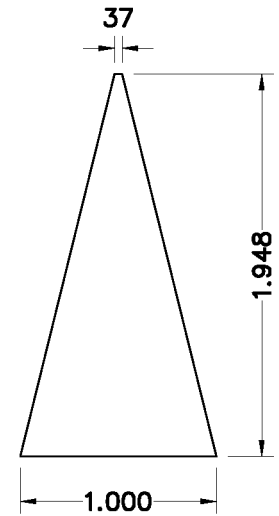

Alle tekeningen z/zn steeds buitencanzicht - Alle afmetingen in mm.

GLASS-SIZES PYRAMIDE 310

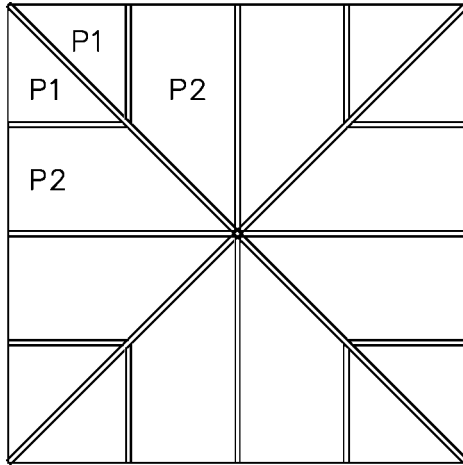

PUNT PY1

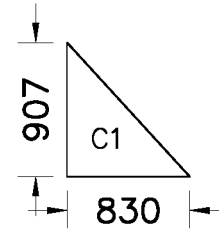

PUNT PY2

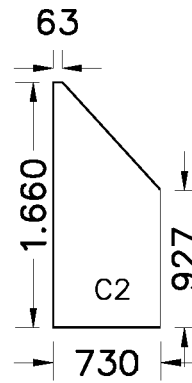

GLASS-SIZES PYRAMIDE 378

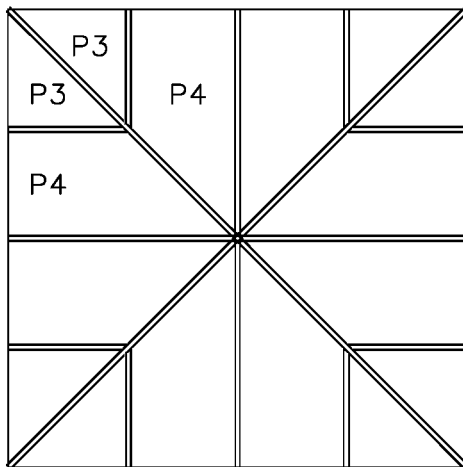

PUNT PY3

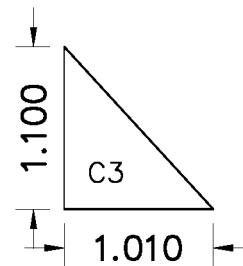

PUNT PY4

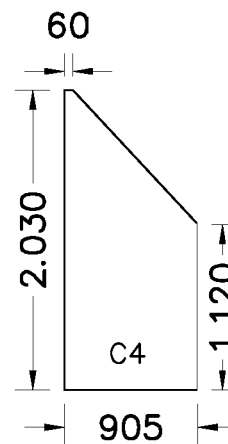

GLASS-SIZES ORANGERIE (MODEL B)

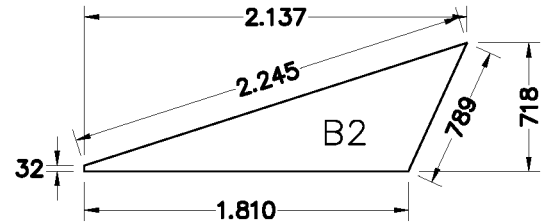
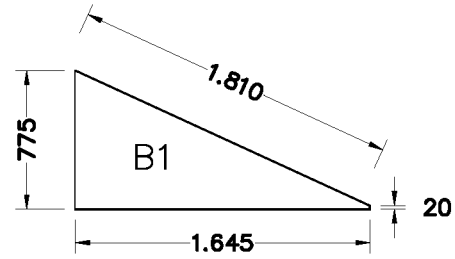
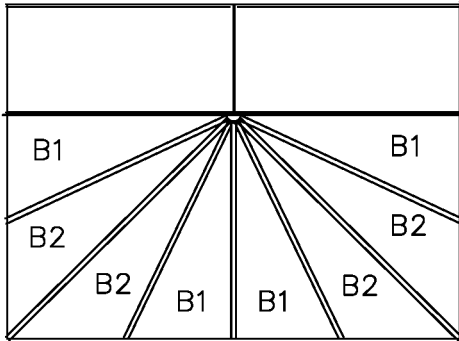

GLASS-SIZES ORANGERIE (MODEL C)

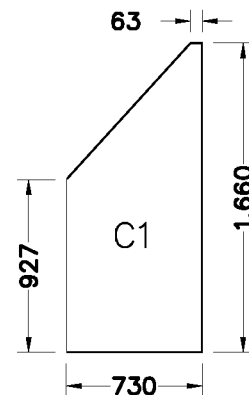
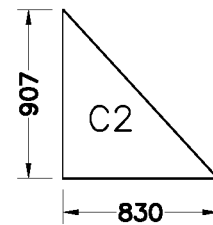
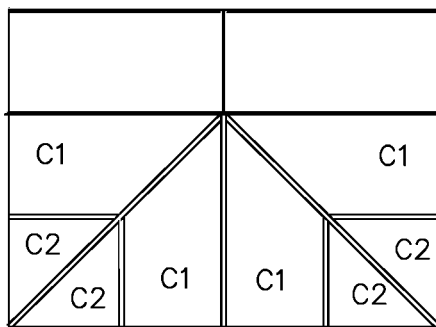

Alle tekeningen zijn steeds buitenaanzicht - Alle afmetingen in mm.

GLASS-SIZES ORANGERIE

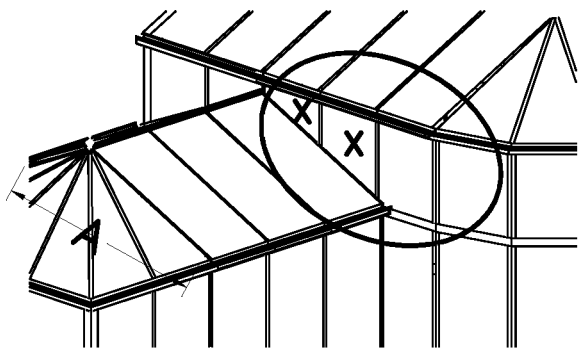

Orangerie A = 310

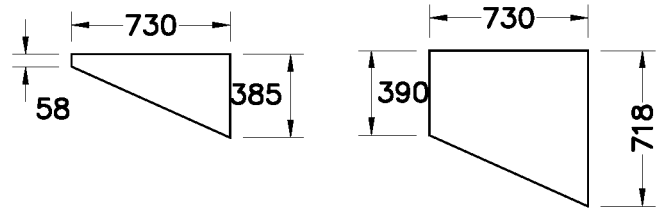

Orangerie A = 378

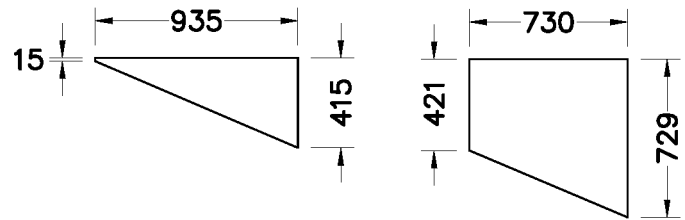

GLASS-SIZES ORANGERIE KATHEDRAL

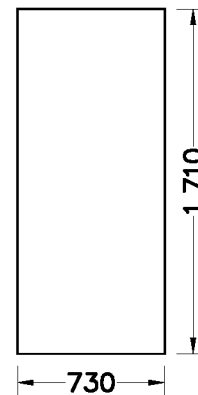
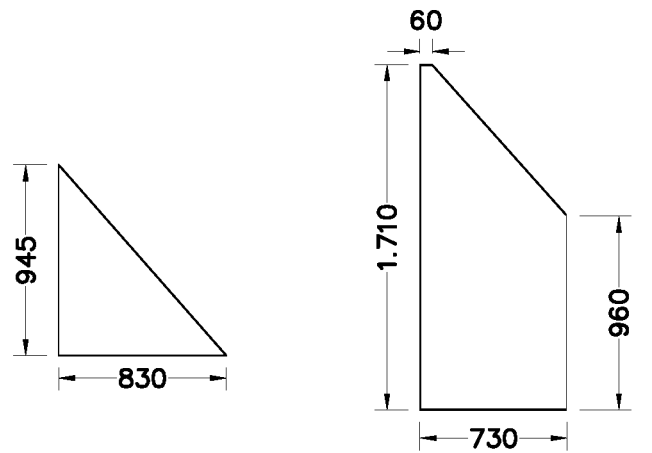
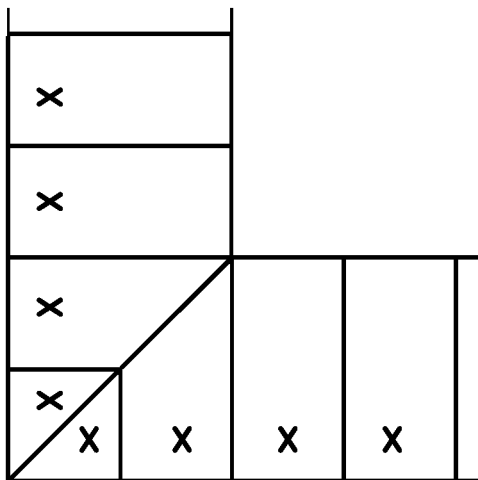

Alle tekeningen zijn steeds buitenaanzicht - Alle afmetingen in mm.

1. GIGANT

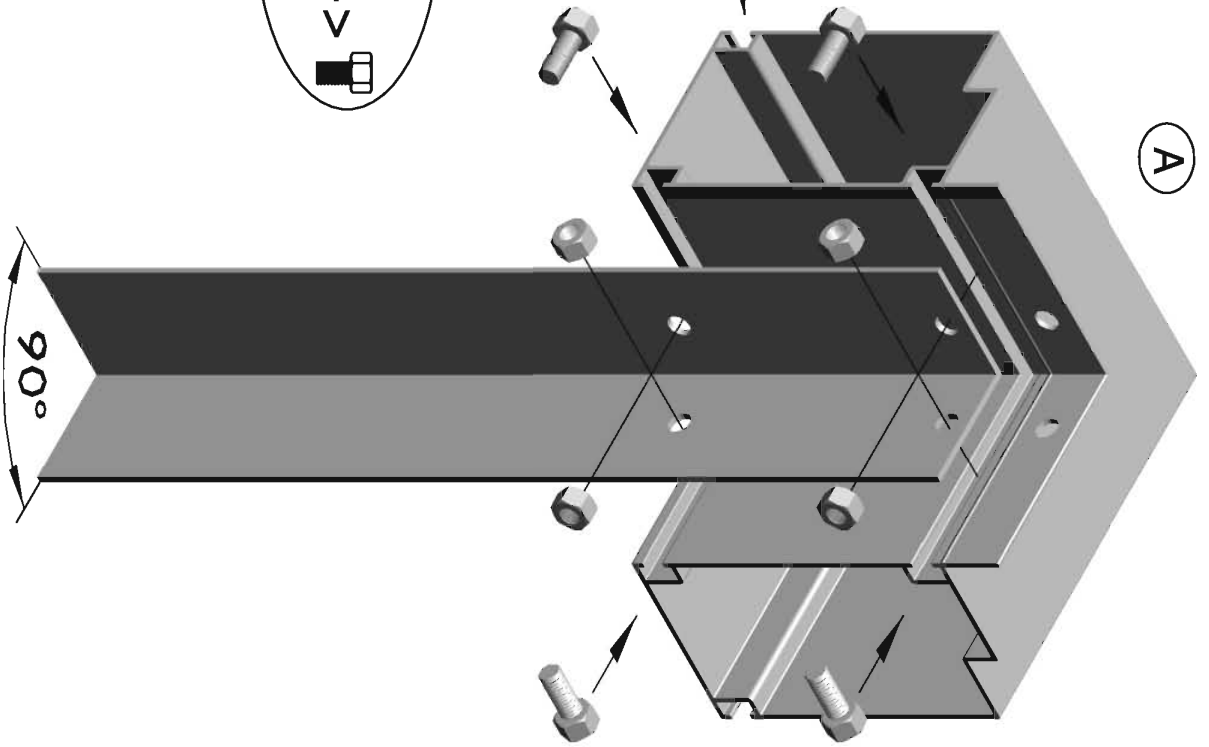
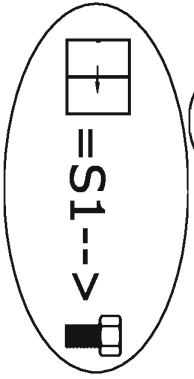
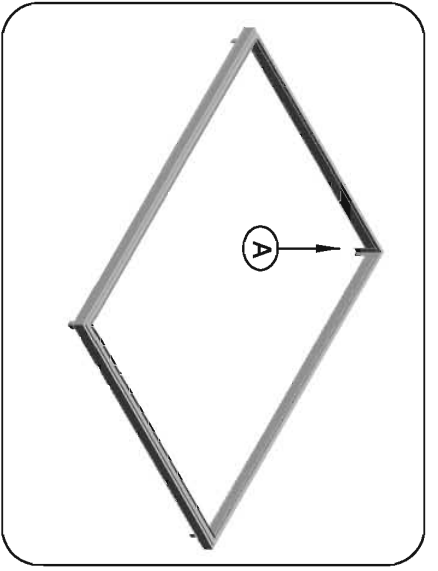

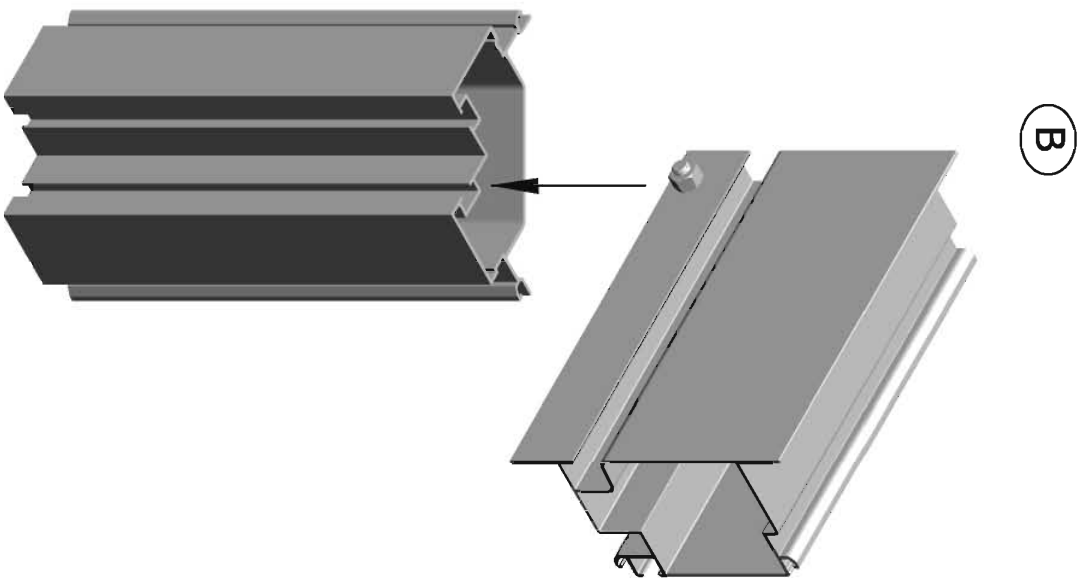
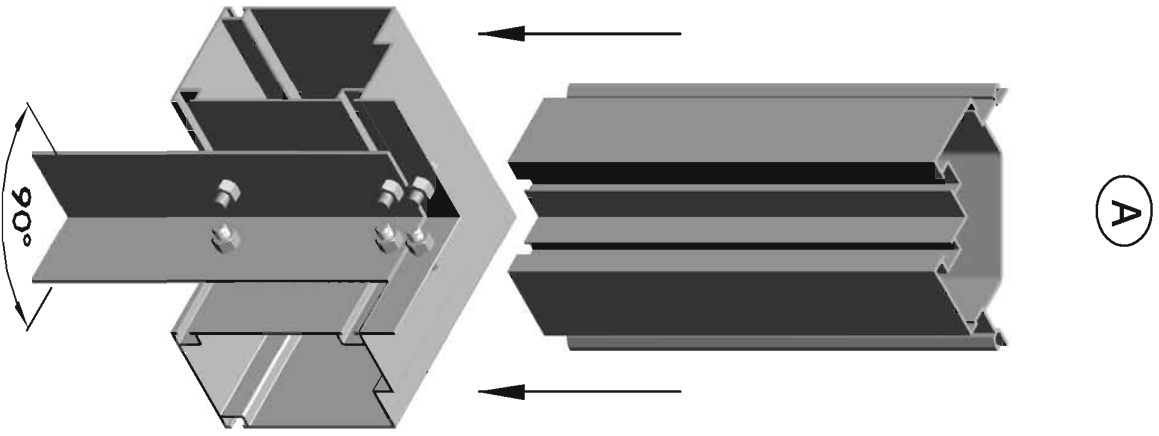
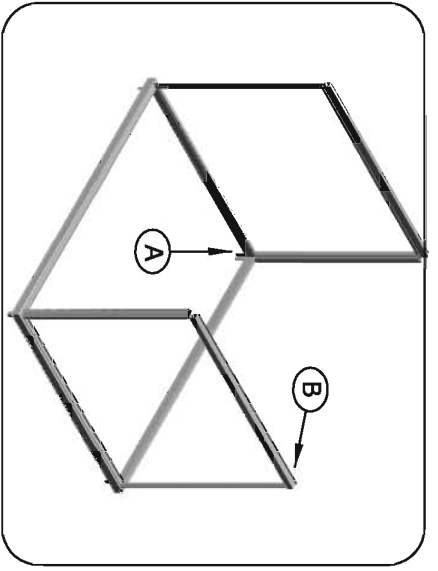

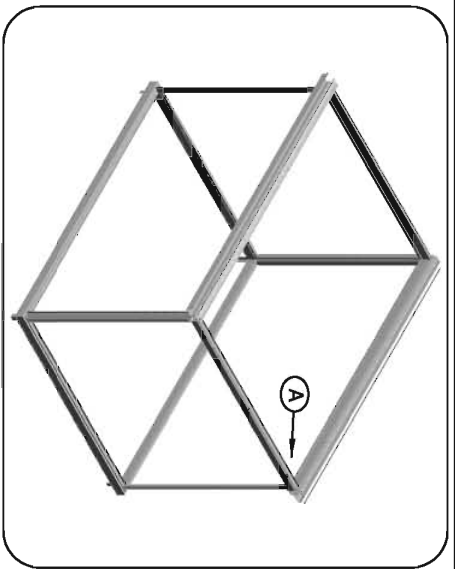

A

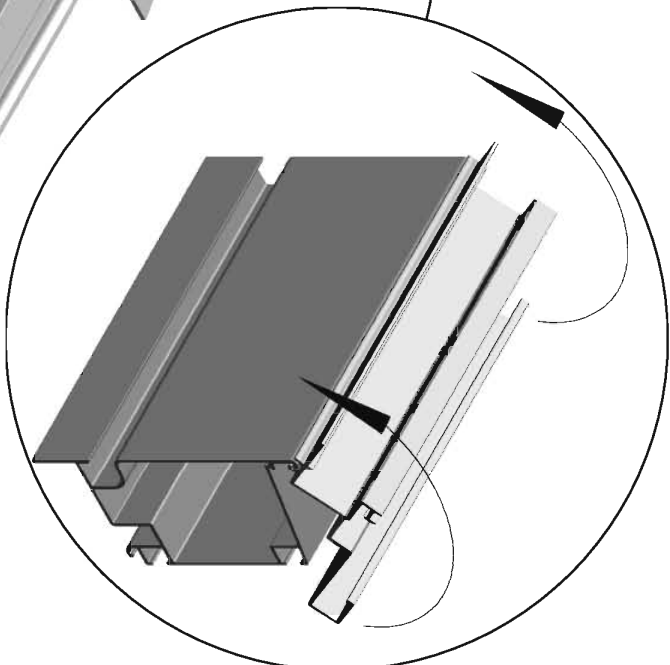
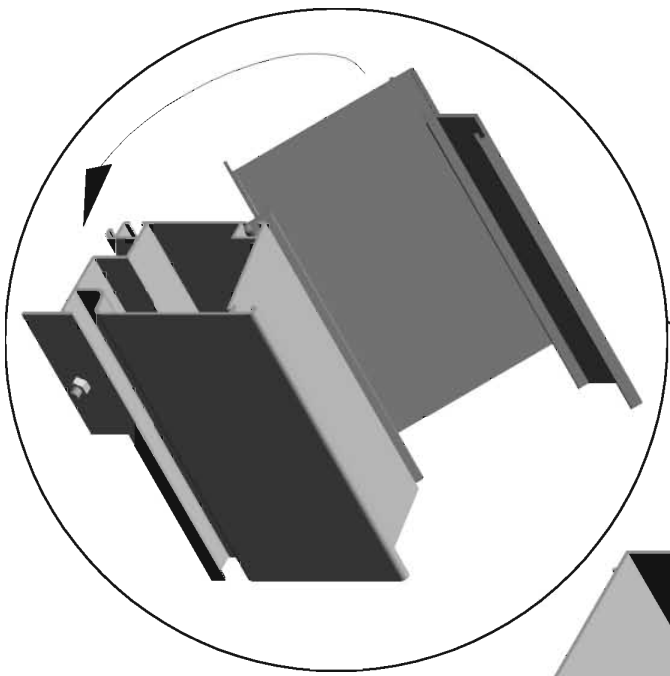
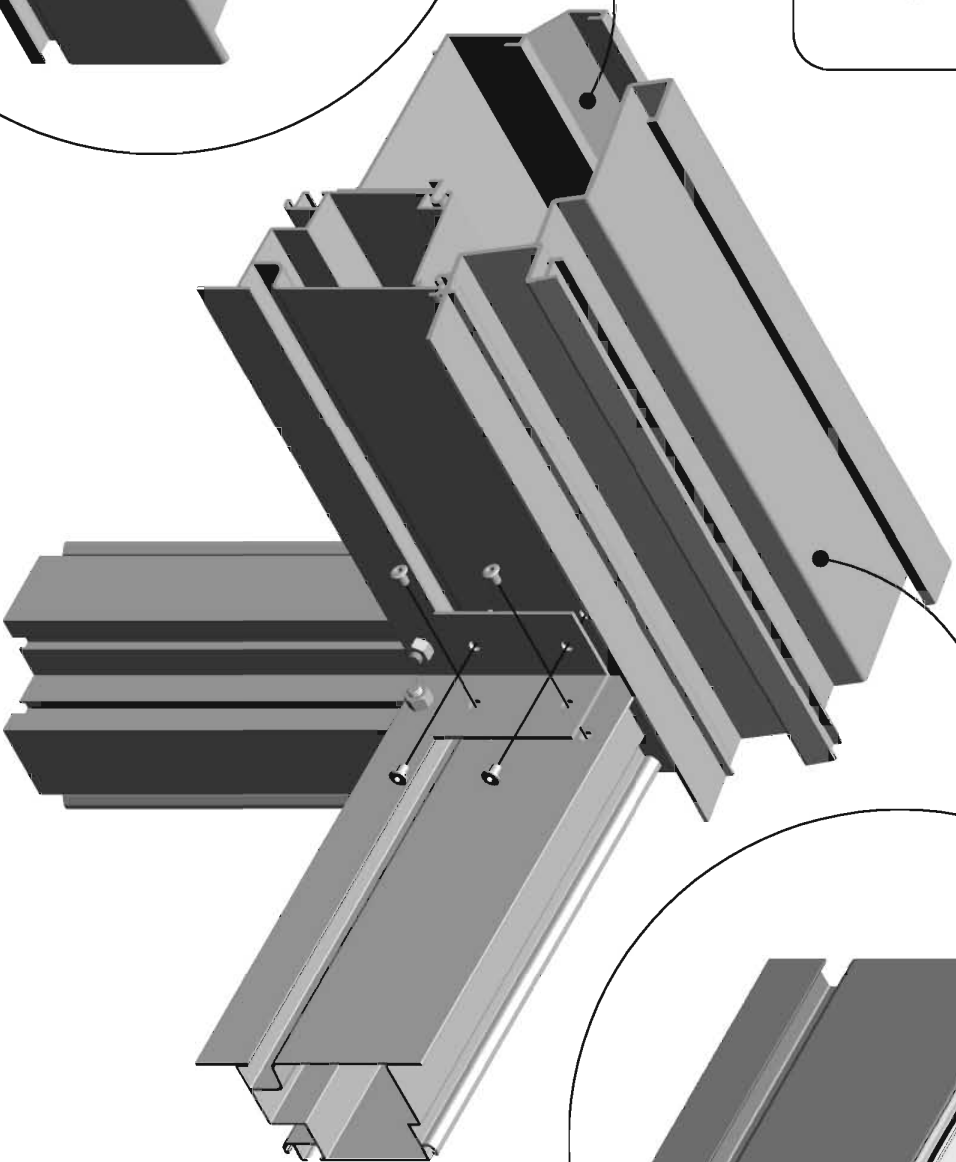

- ii Schuifdeur-Porte Coulisante-Schiebetür-Sliding door =S1
- ii Skydedør-Skyvedør-Skugvæv-Porta scorrevole
- ii Schuifraam-Fenêtre Coulisante-Schiebefenster-Sliding window =SR1
- ii Skydevindue-Skyvefönster-Skugvindue-Finestra scorrevole

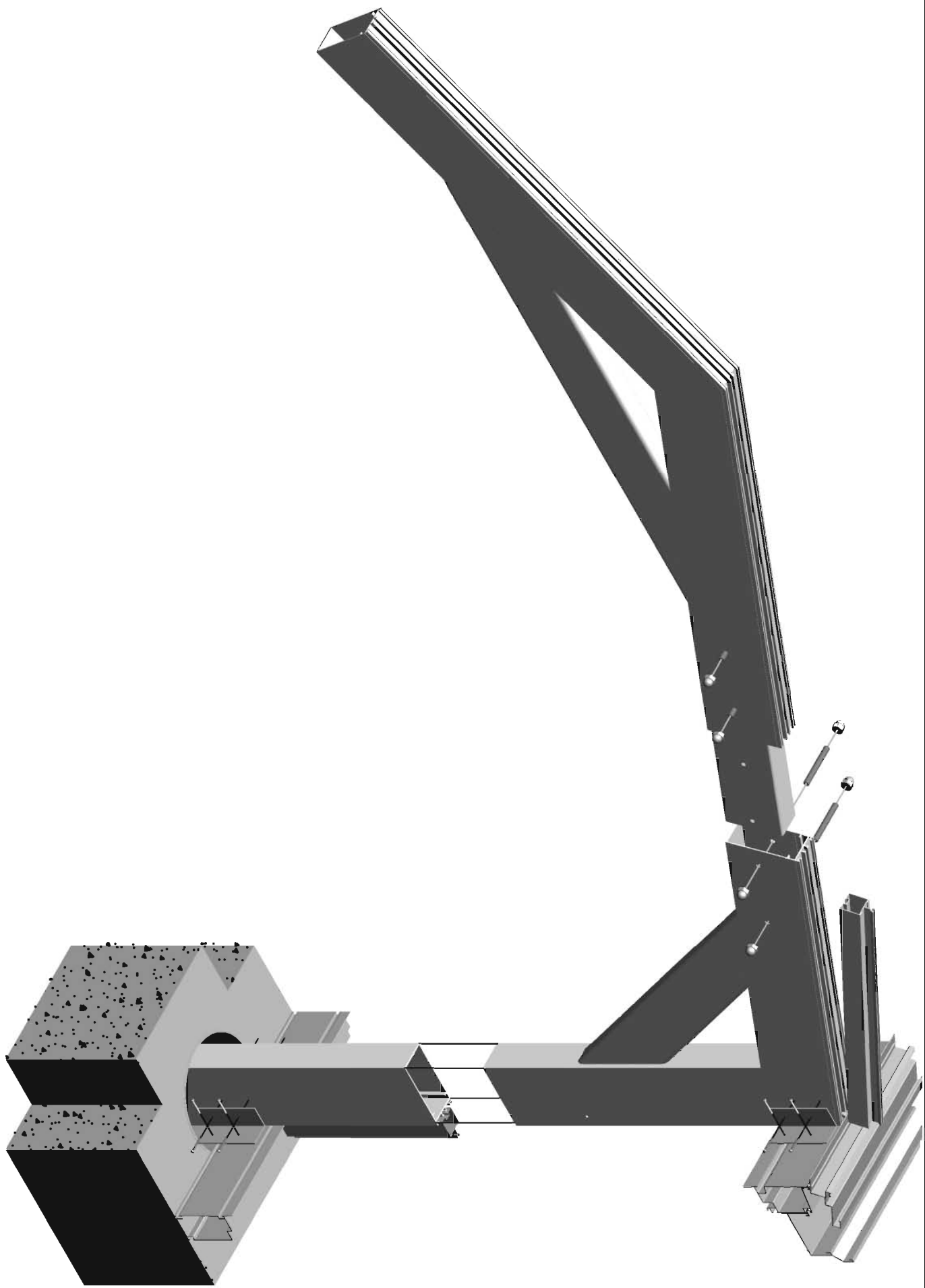

G4

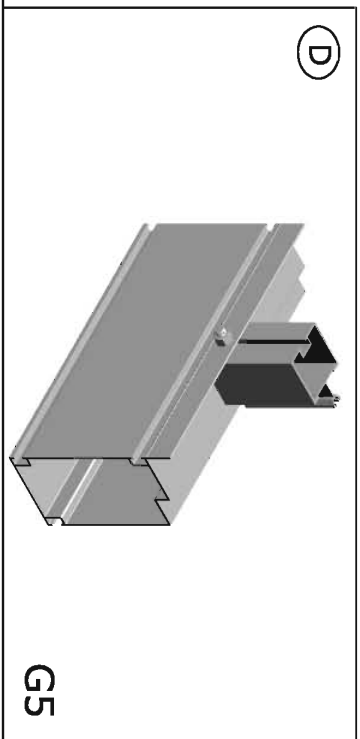
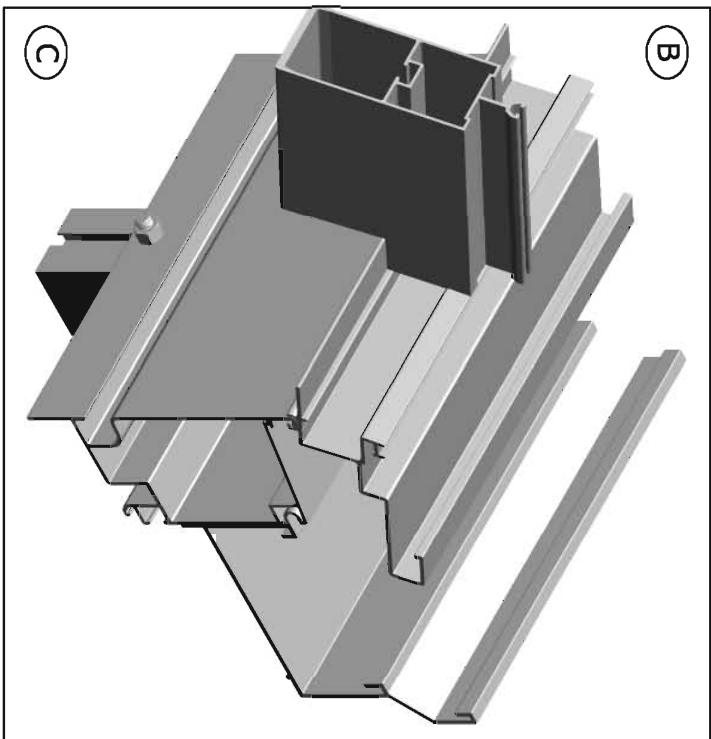
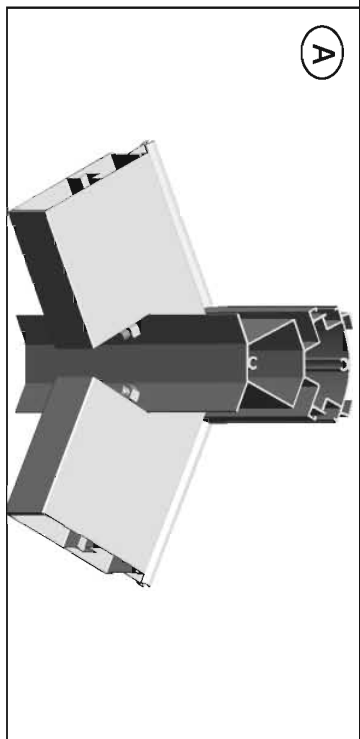
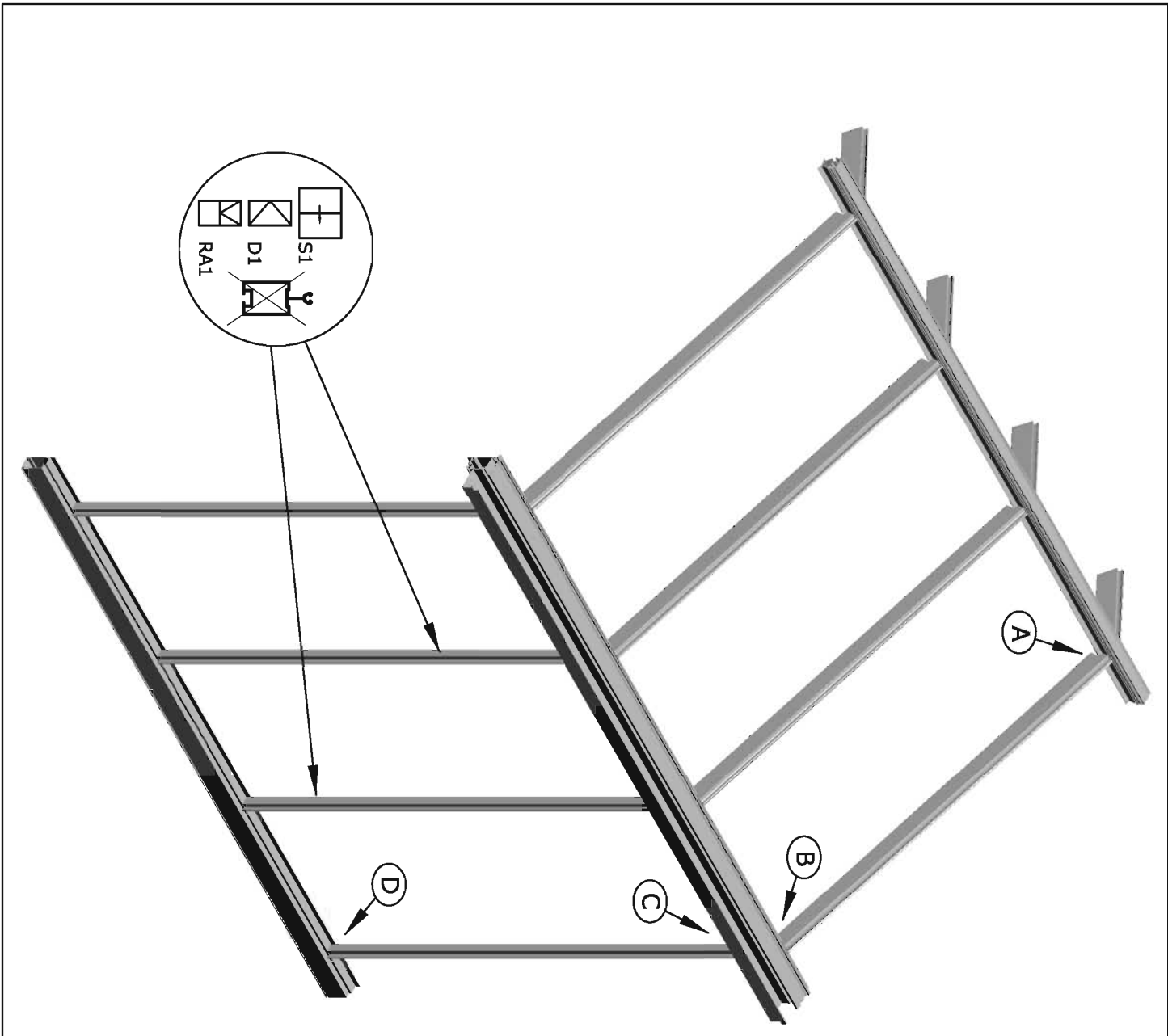

G5

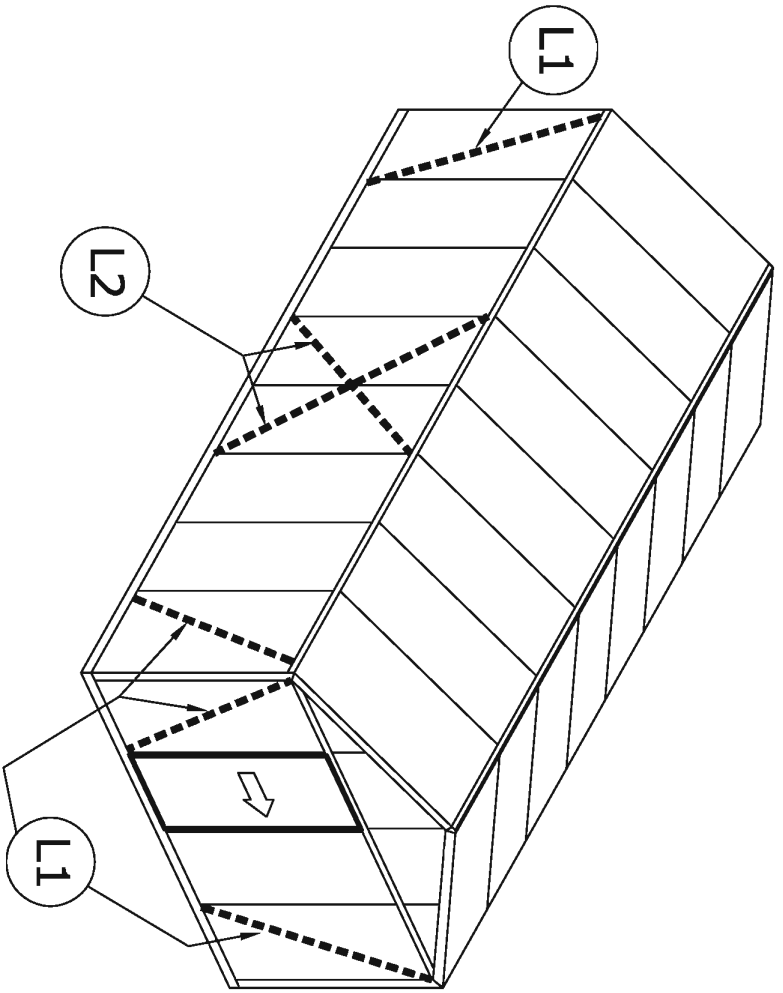

L1 = 1975mm
L2 = 2700mm

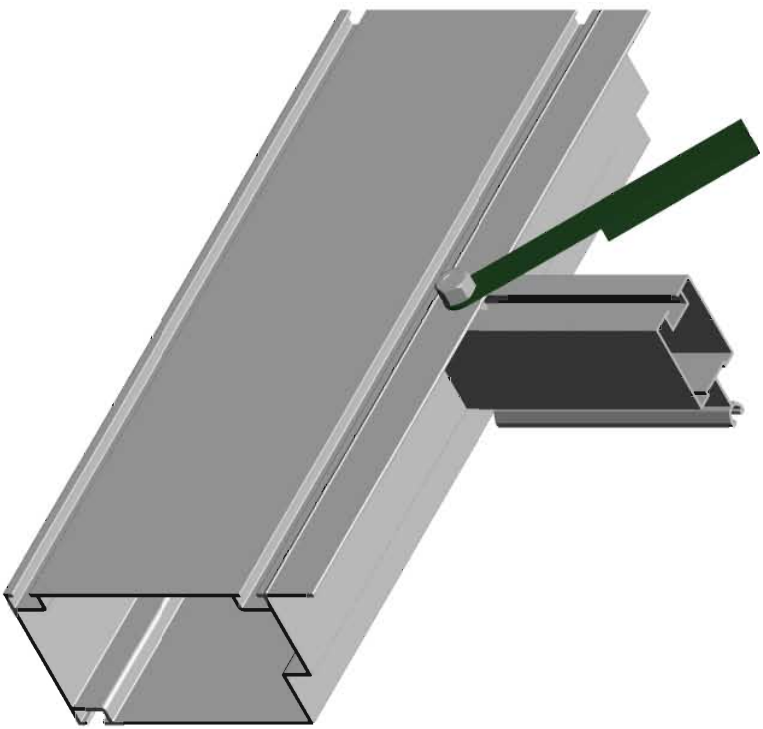

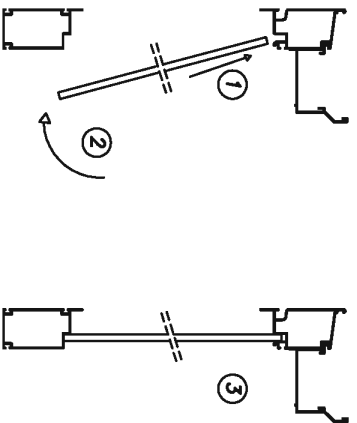
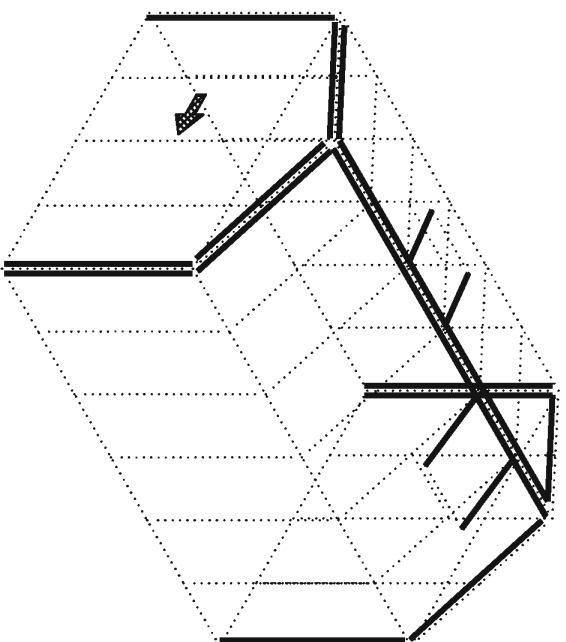
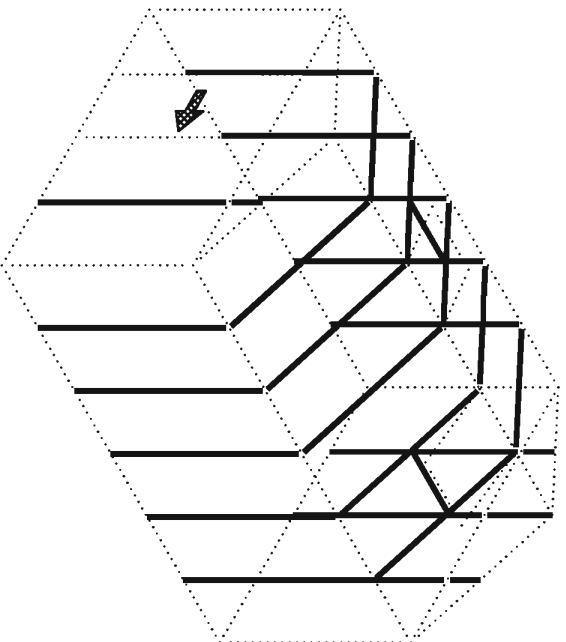
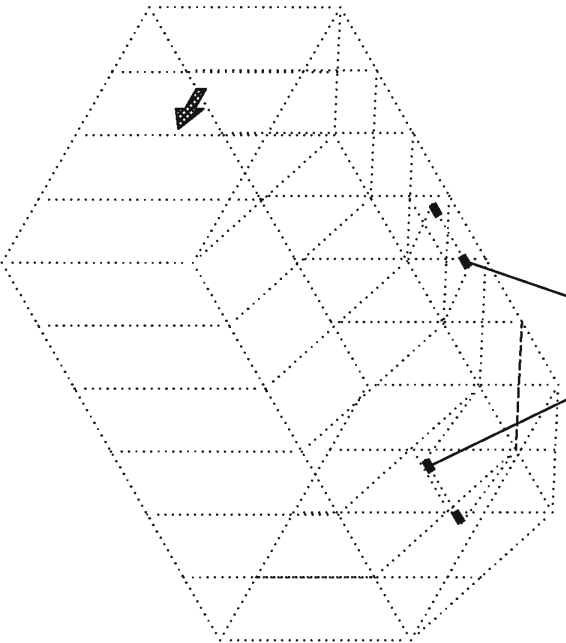
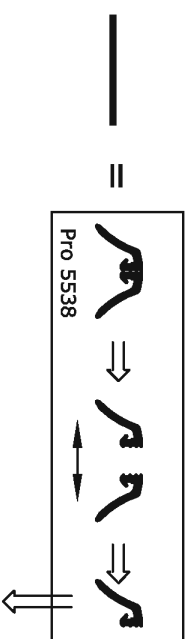
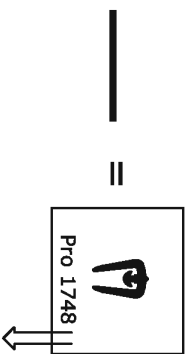
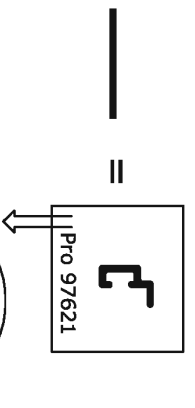

④

!!! K-glas: ● = Inside / Innerseite / Intérieur

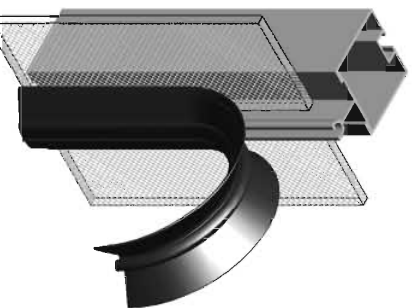

G7

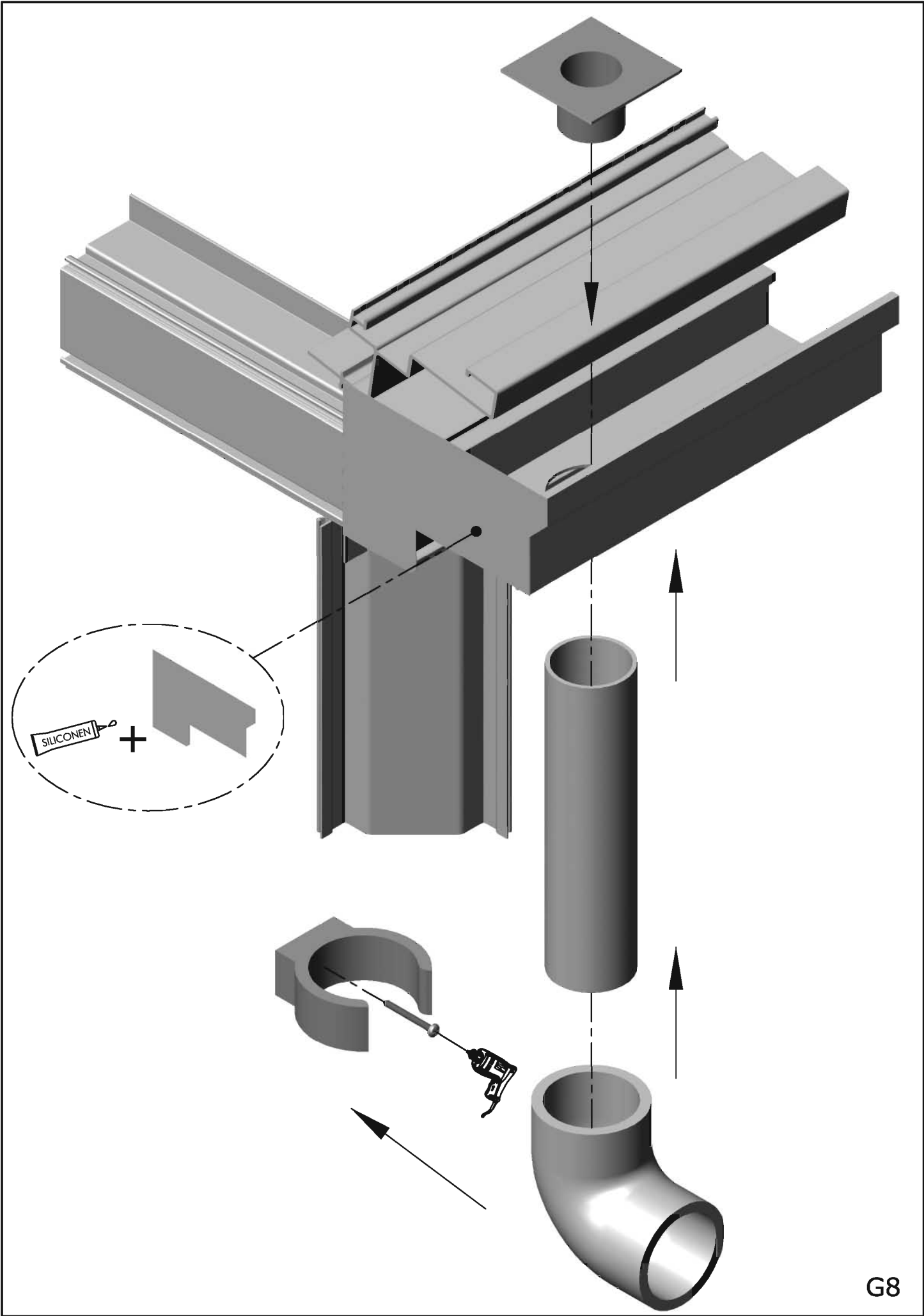

2. ORANGERIE

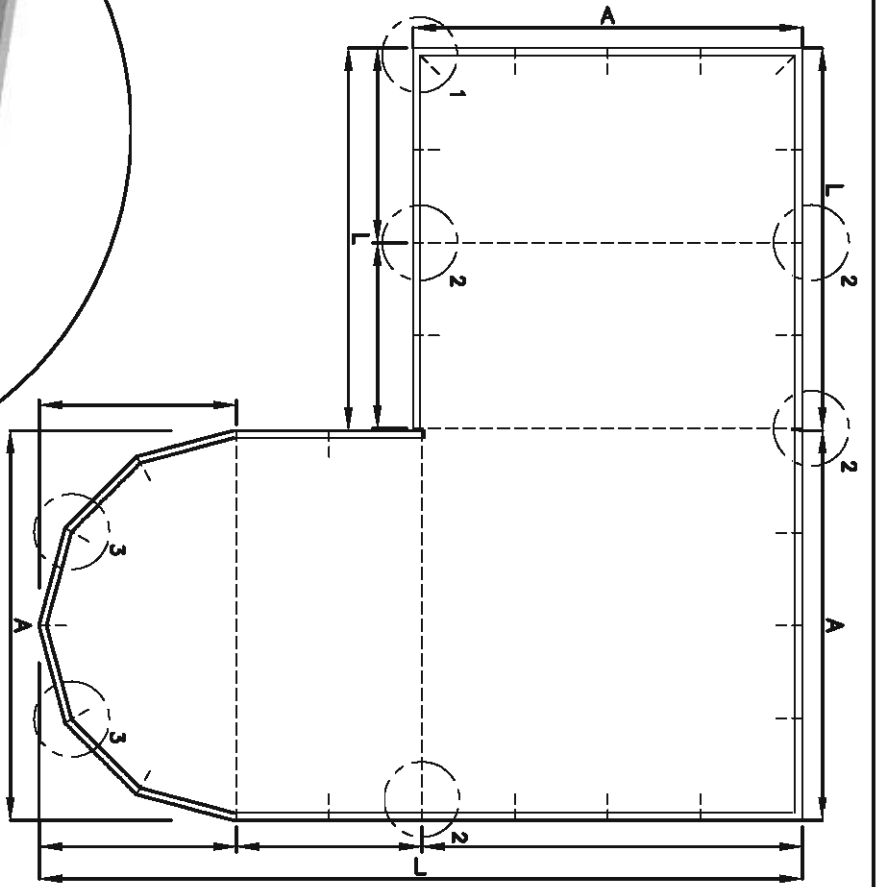

Detail-1

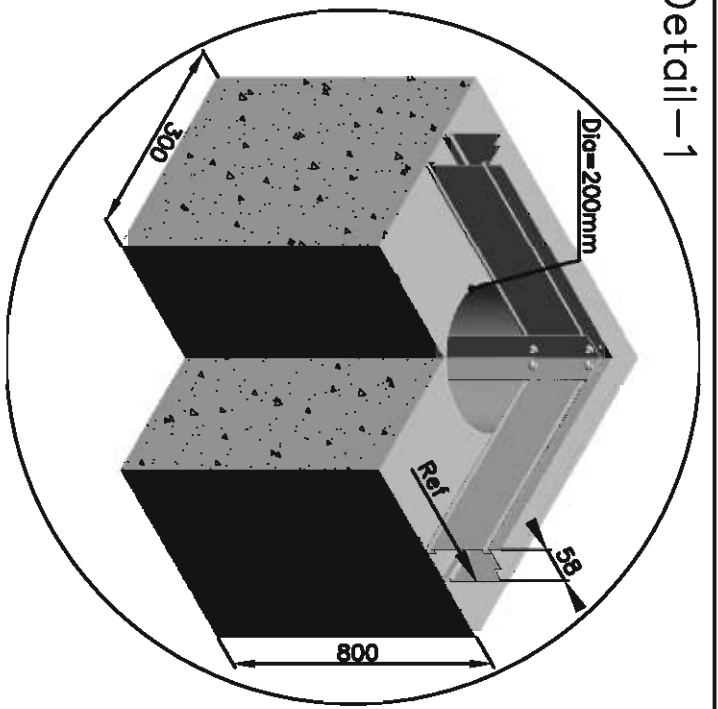

Detail-2

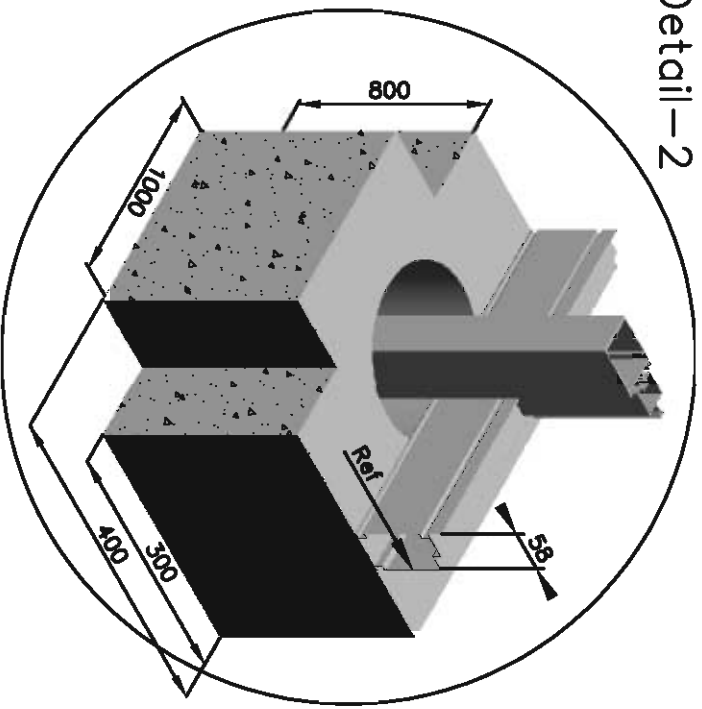

Detail-3

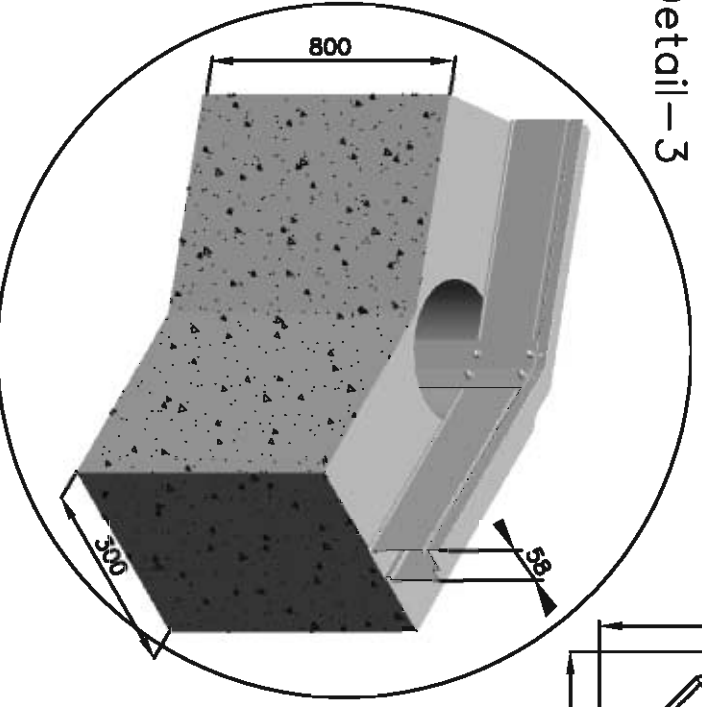

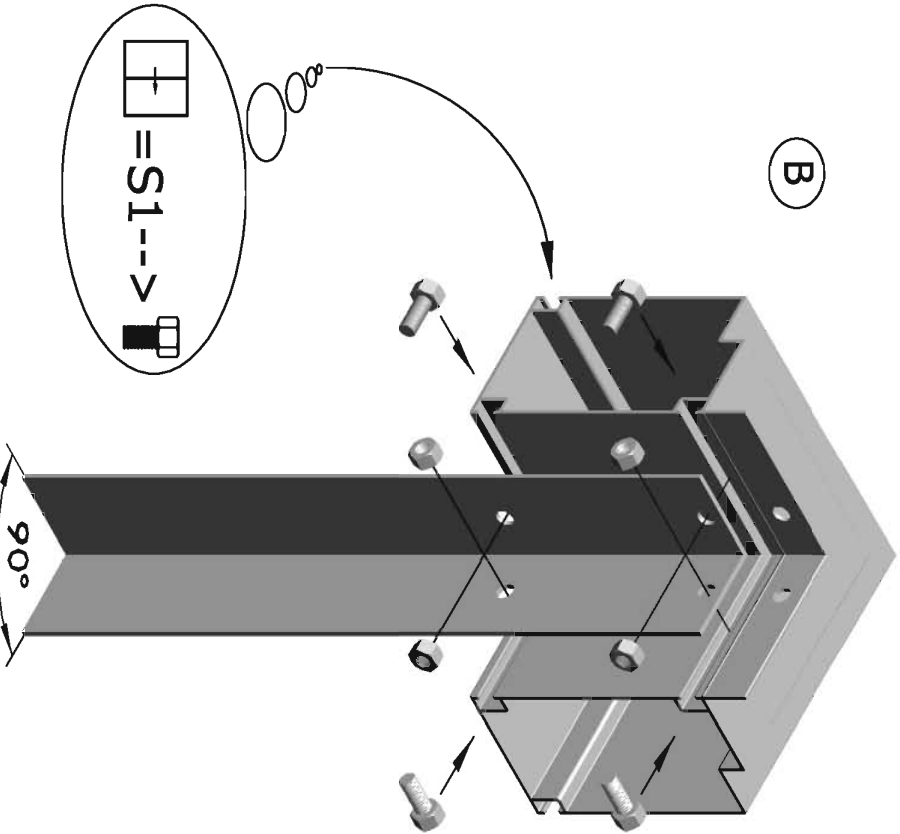
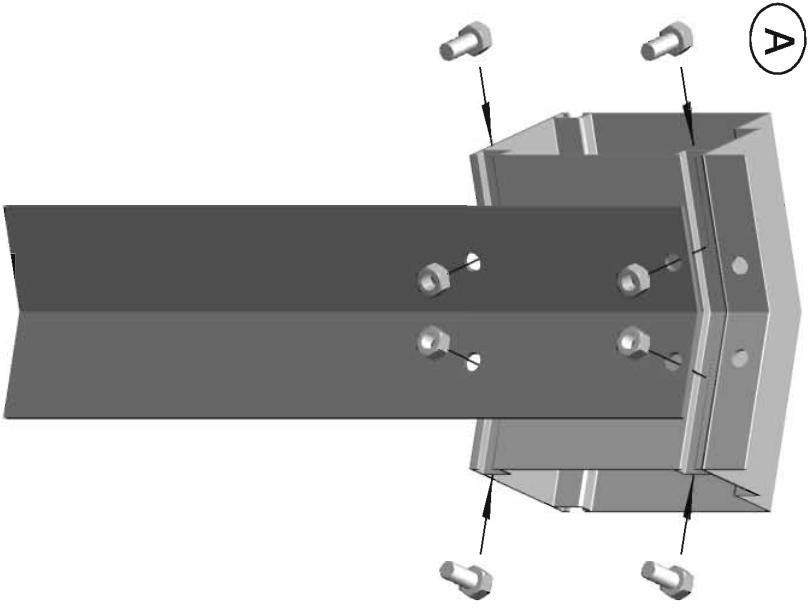
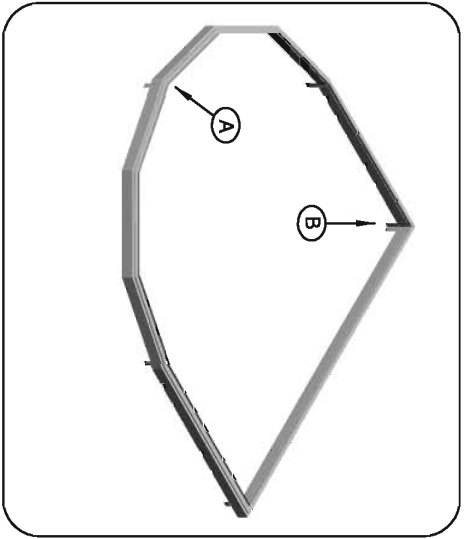

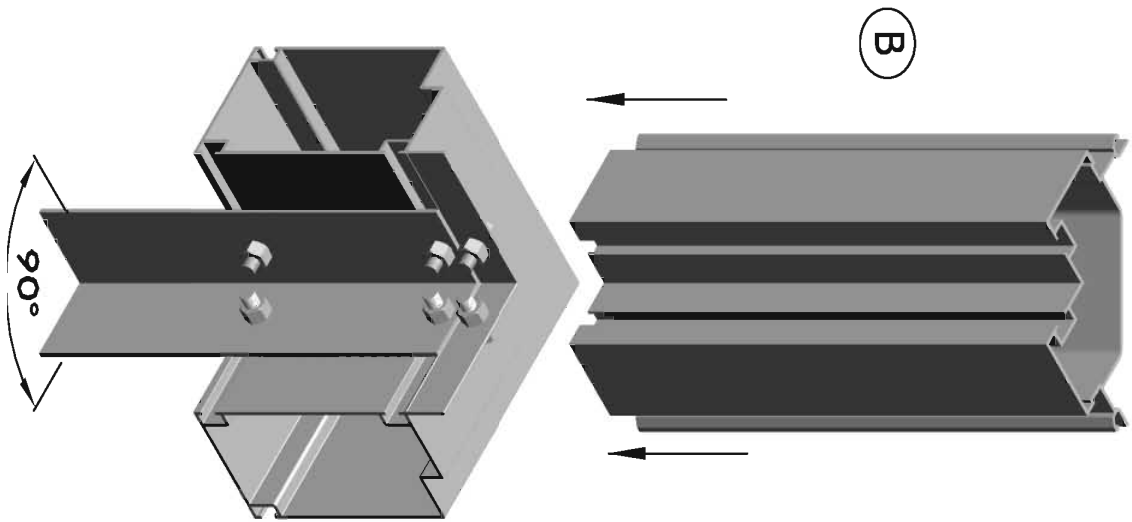
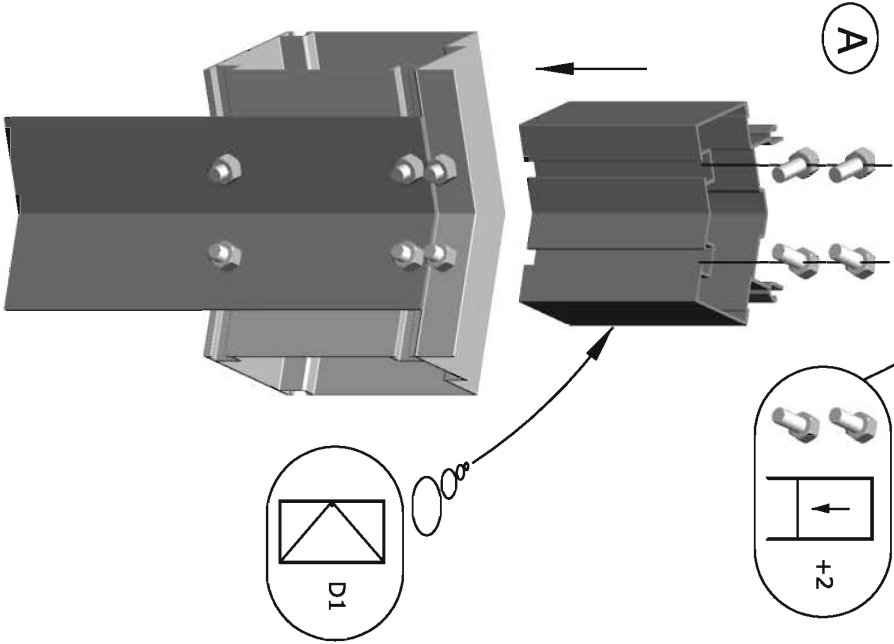
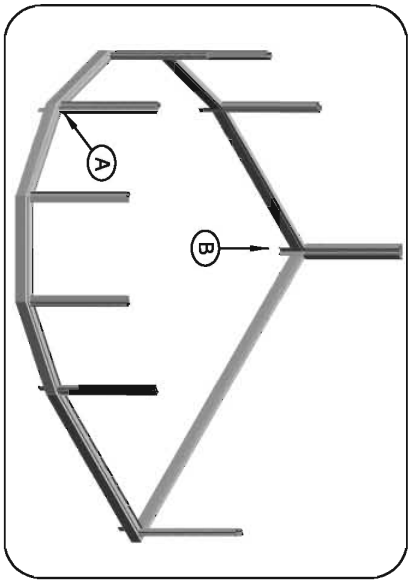

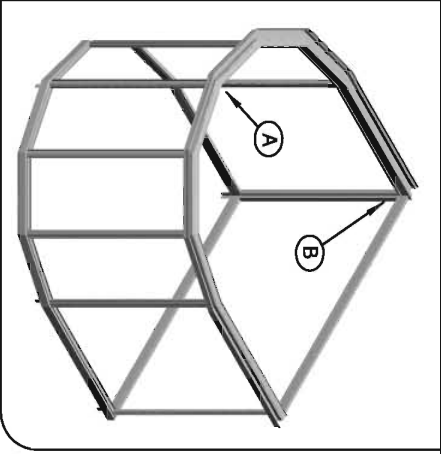

A

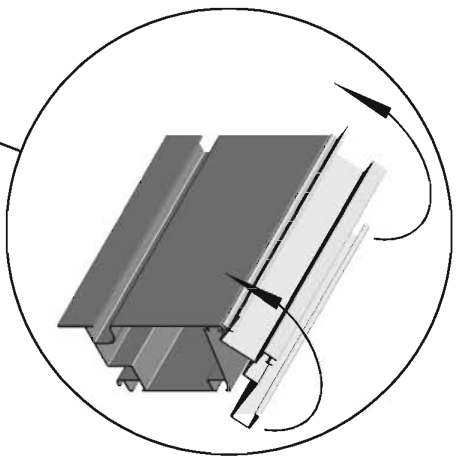
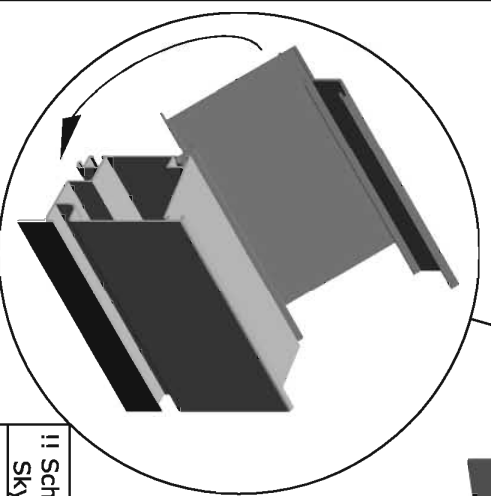
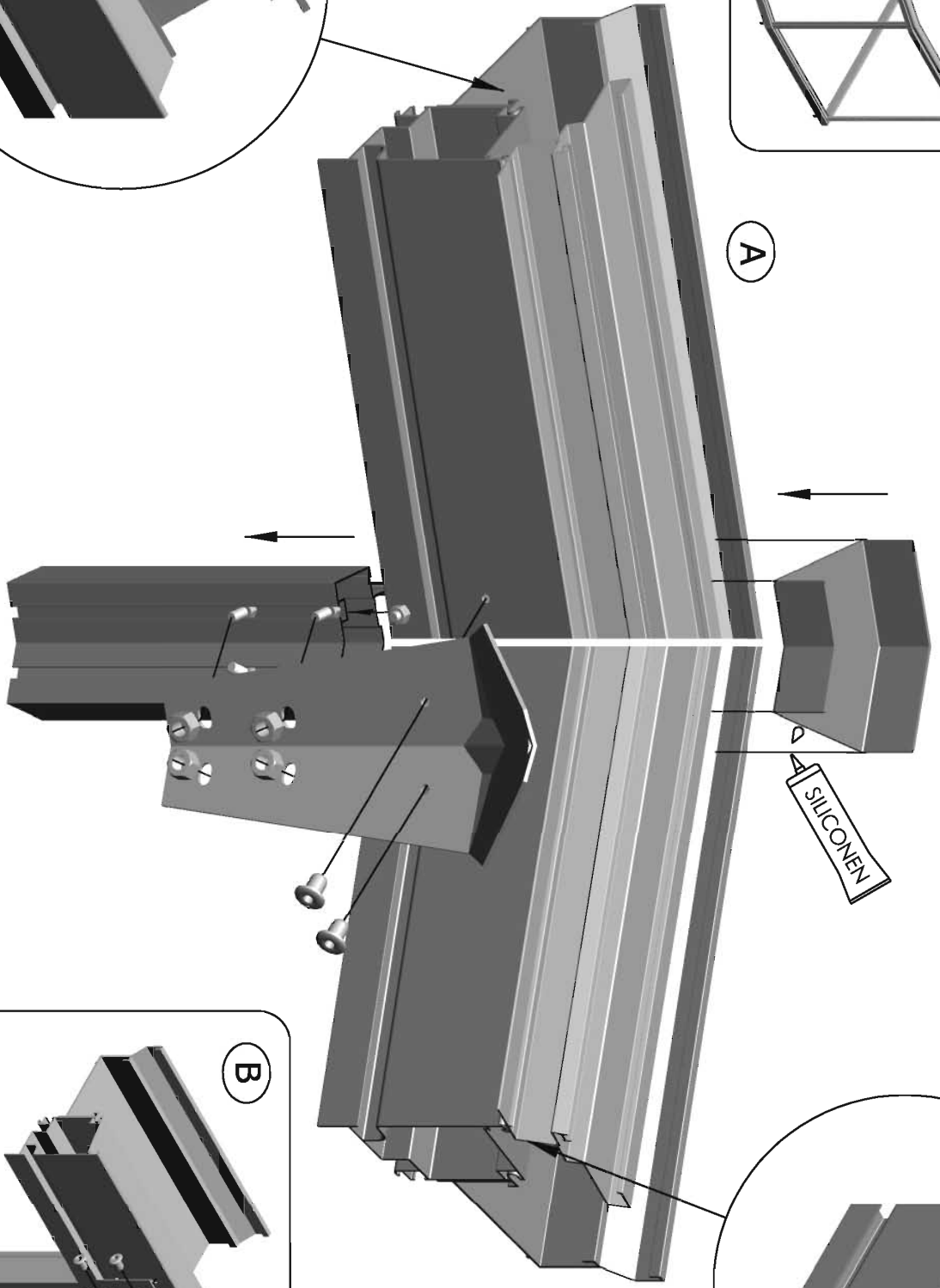

B

- ii Schuifdeur-Porte Coulisante-Schiebetür-Sliding door =S1
- ii Skydedør-Skyvedør-Skuggvæv-Porta scorrevole
- ii Schuifraam-Fenêtre Coulisante-Schiebefenster-Sliding window =SR1
- ii Skydevindue-Skyvefönster-Skuggvindue-Finestra scorrevole

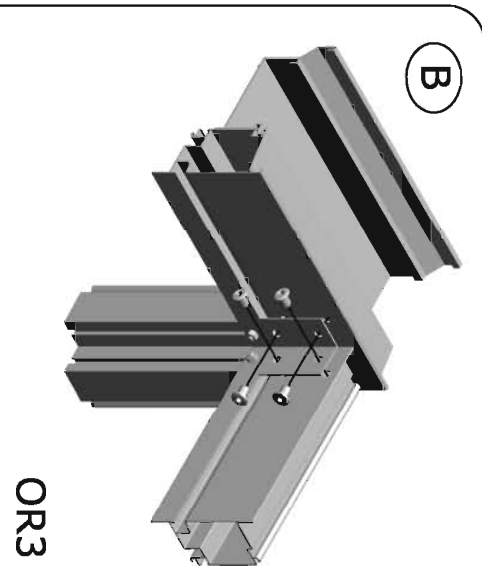

OR3

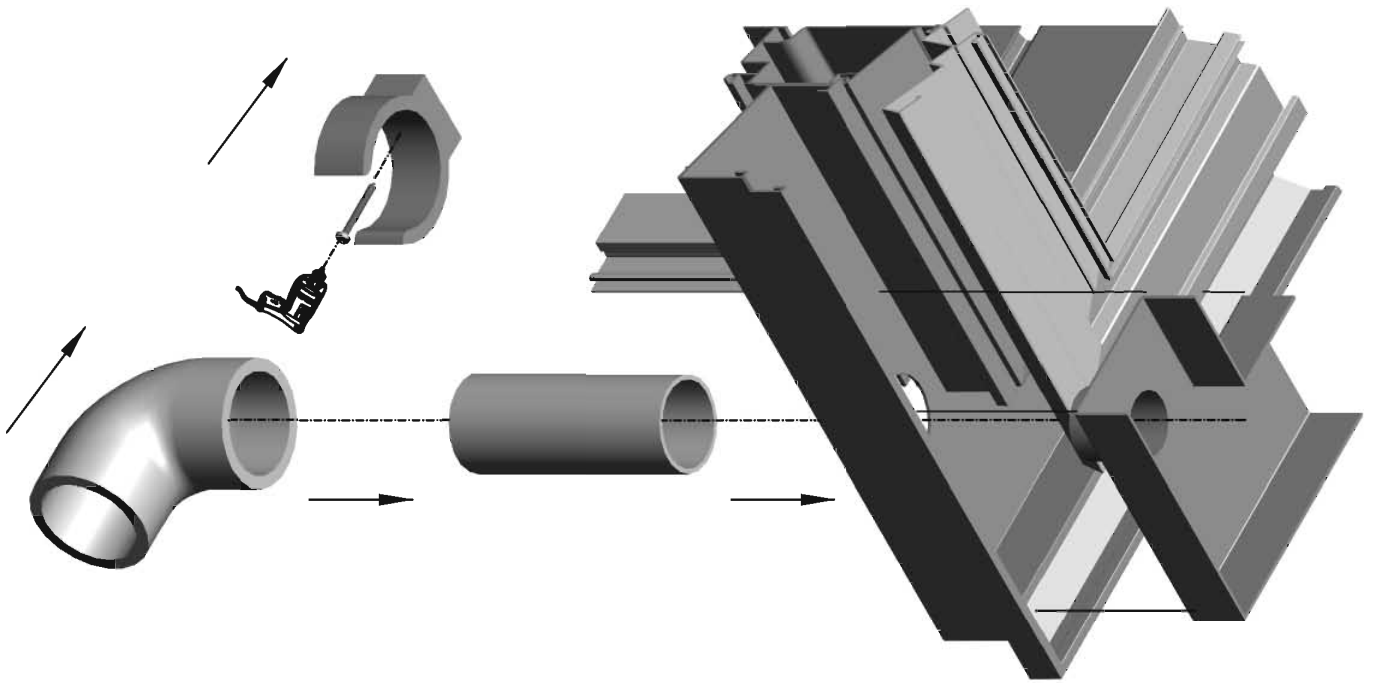
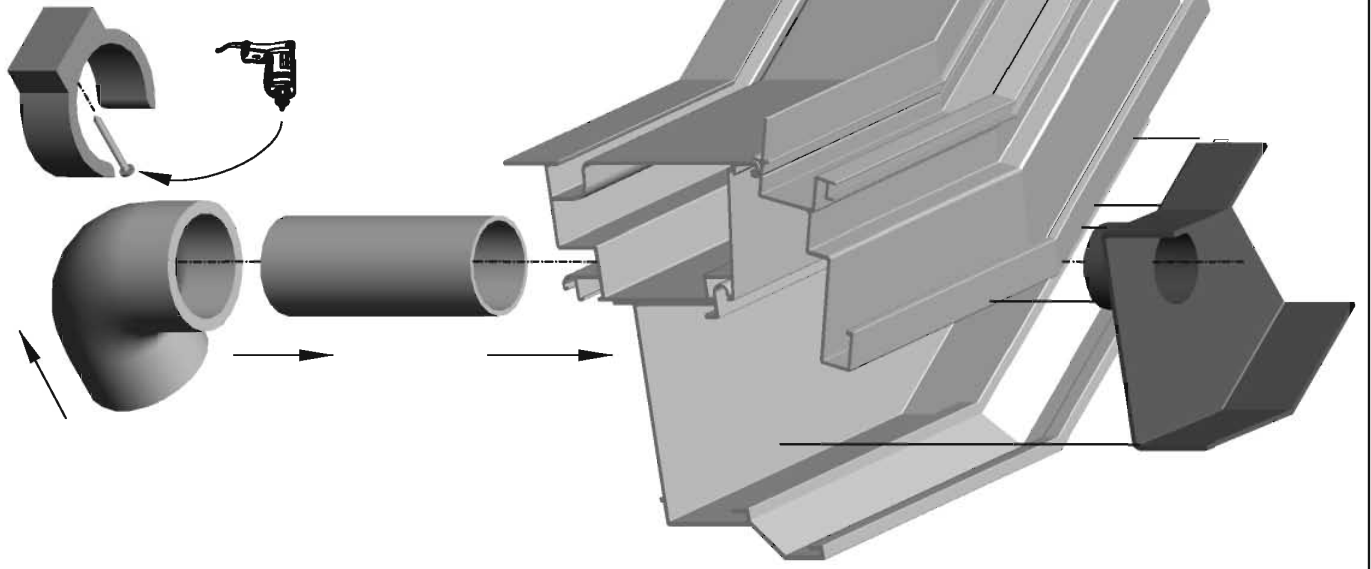

OR4

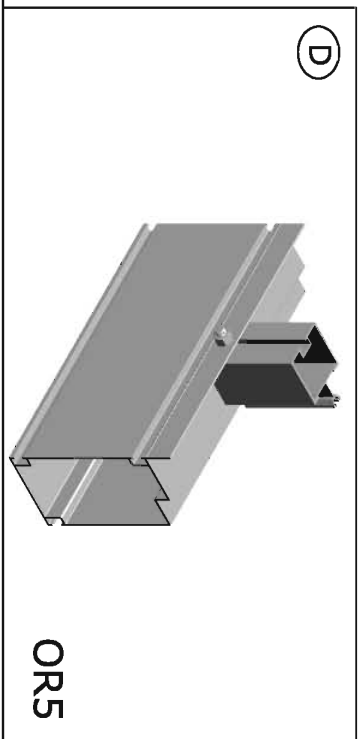
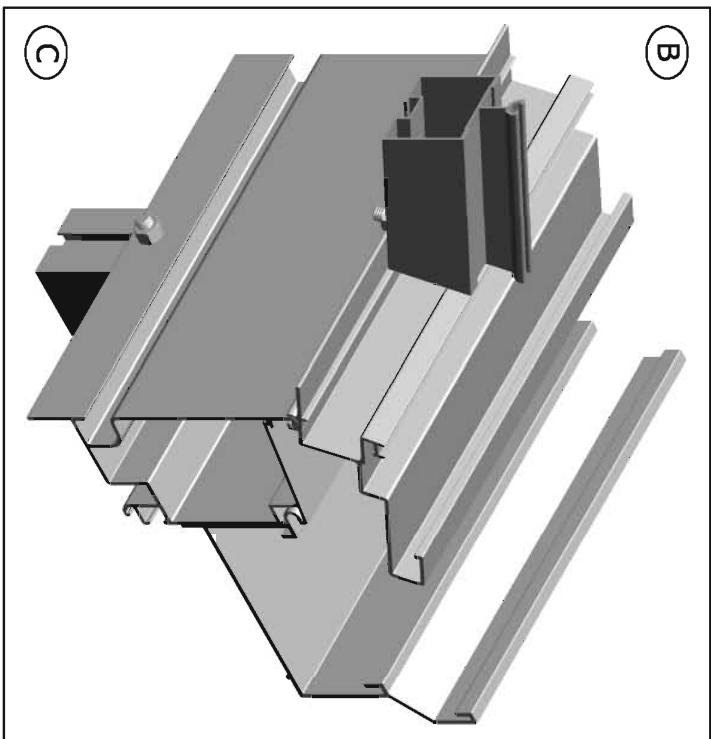
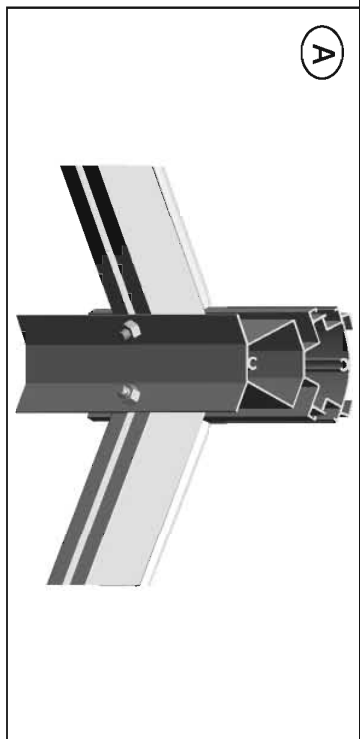
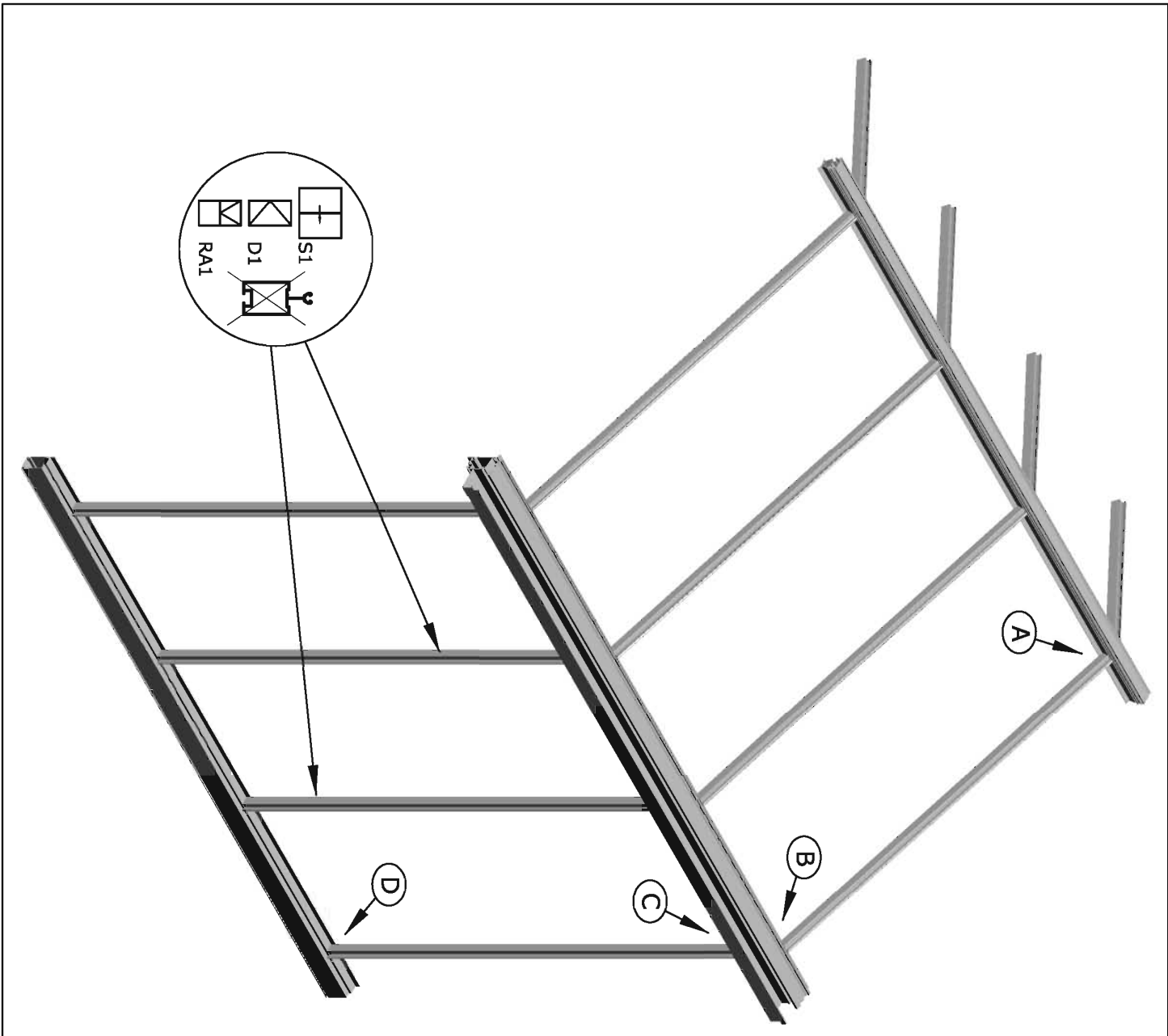

OR5

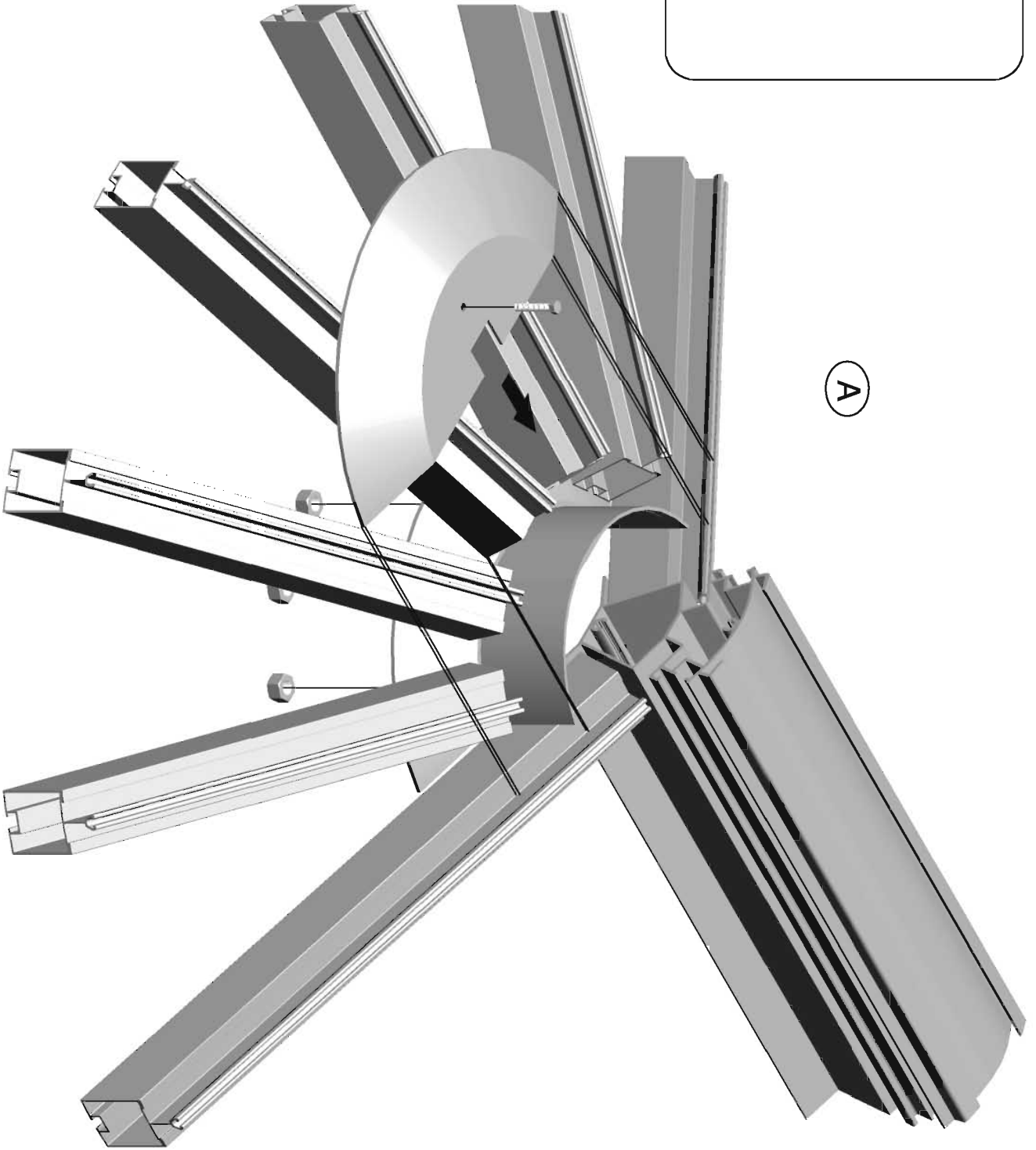
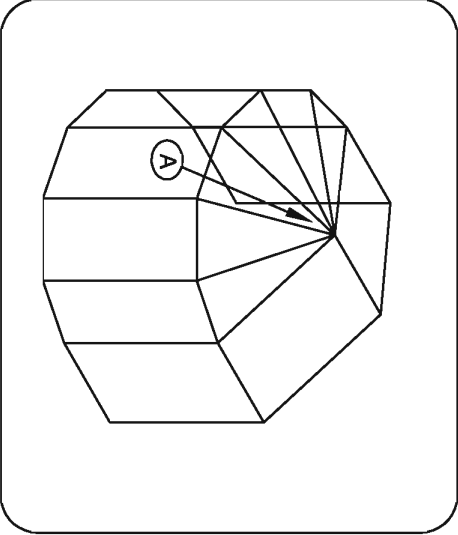

OR6

TYPE B

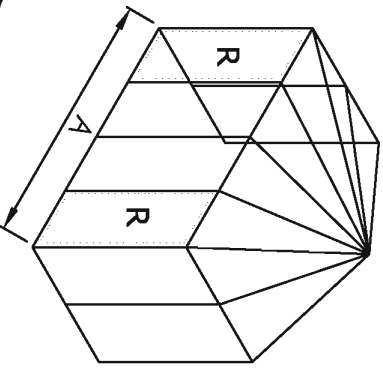

TYPE C

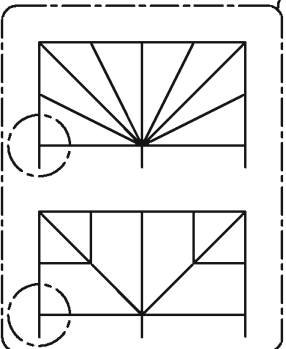
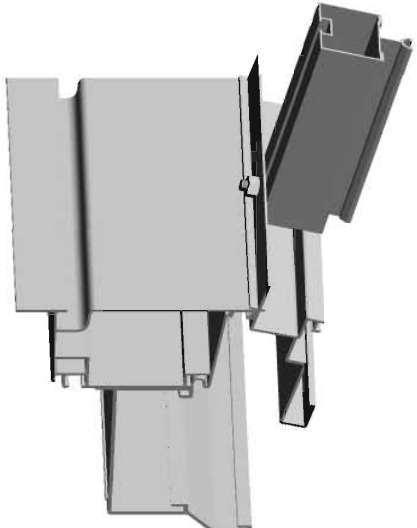
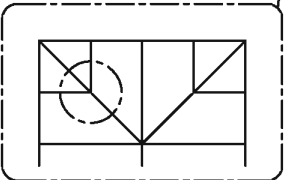
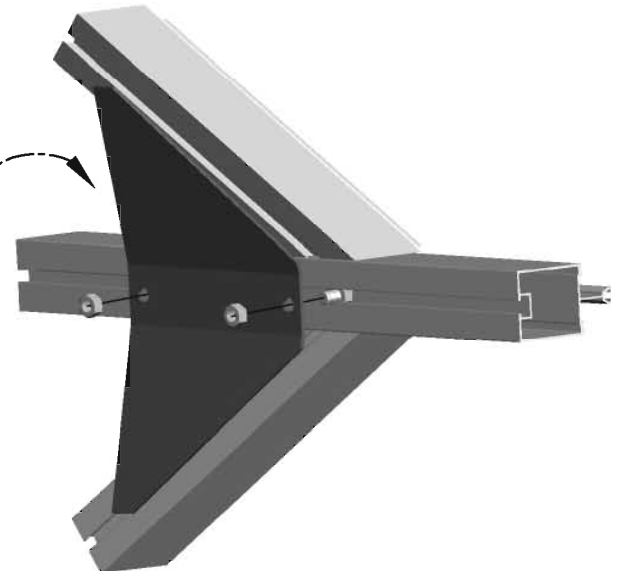
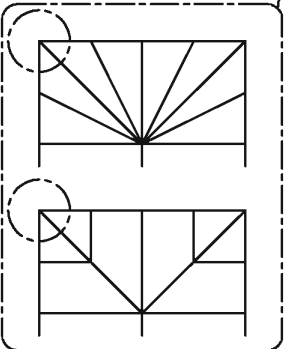
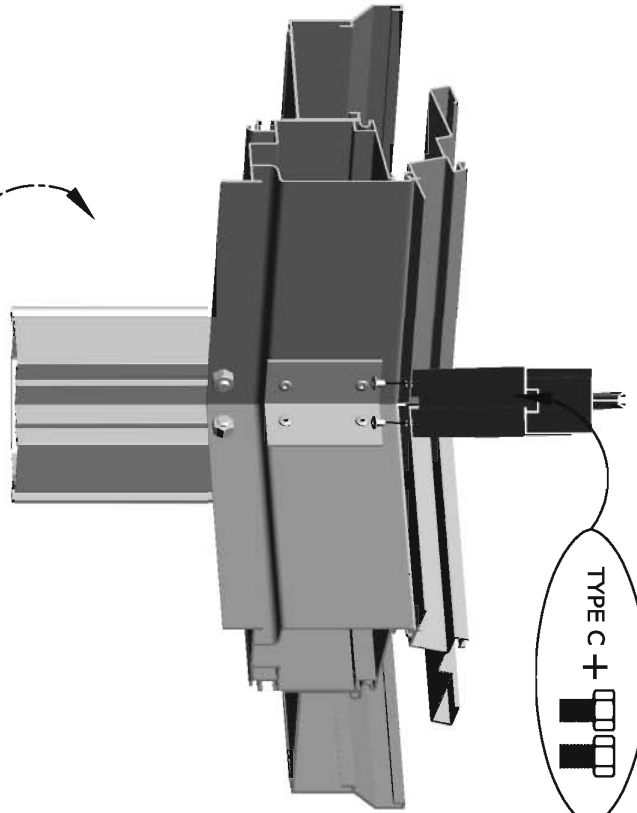
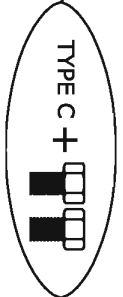
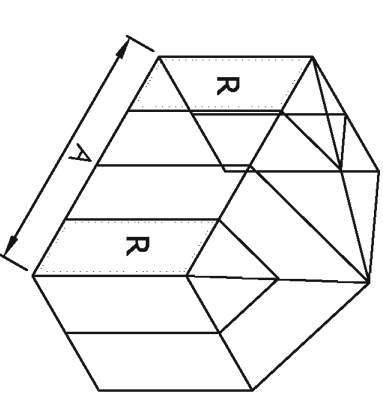

! (Warning symbol)

A=310

A=378

R=730 X 1850

R=698 X 1850

⚡ (Lightning bolt symbol)

OR7

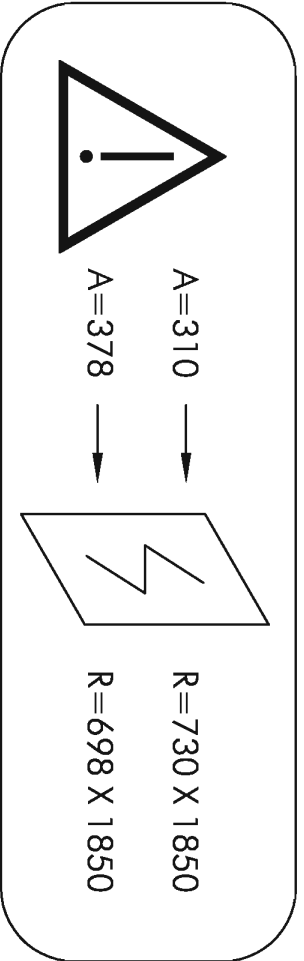
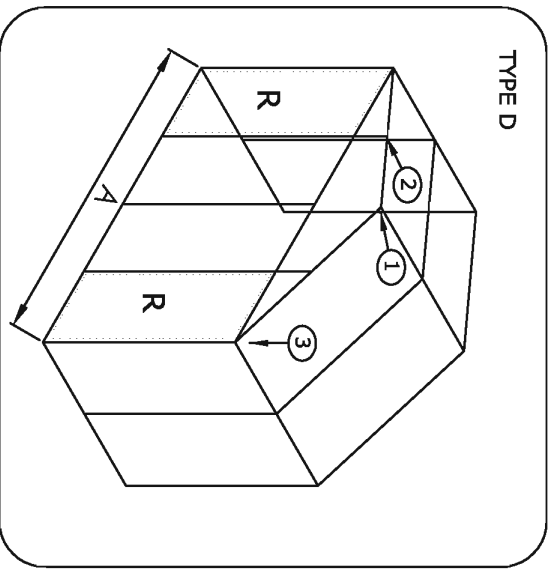

1

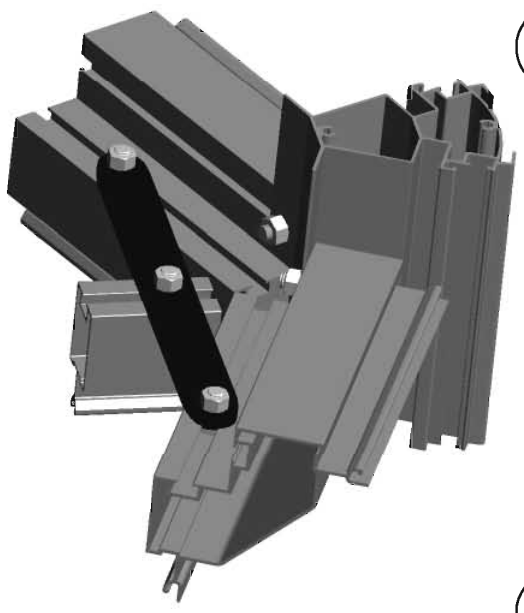

2

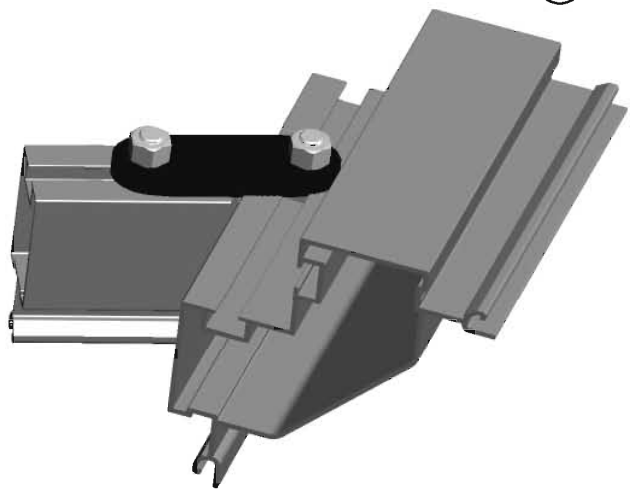

3

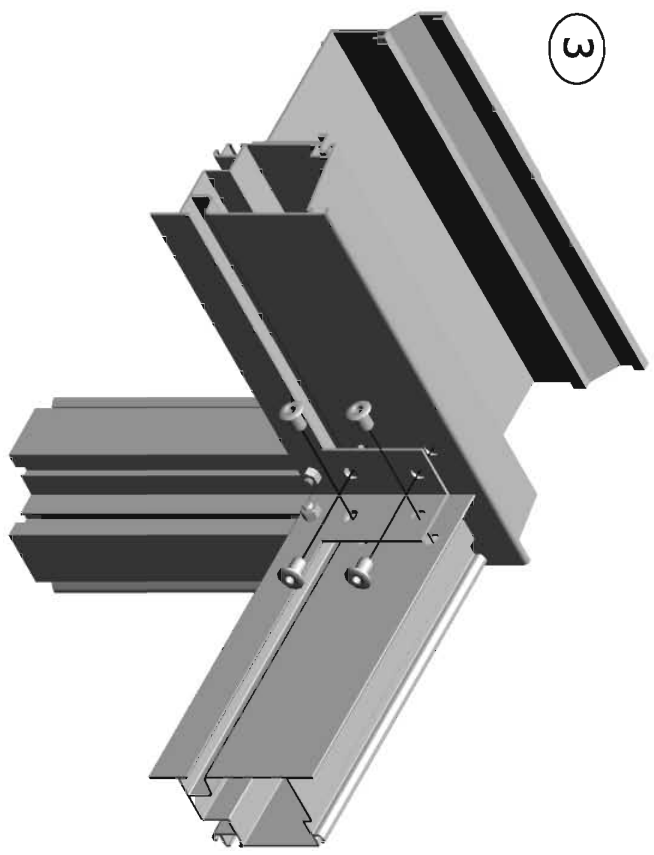

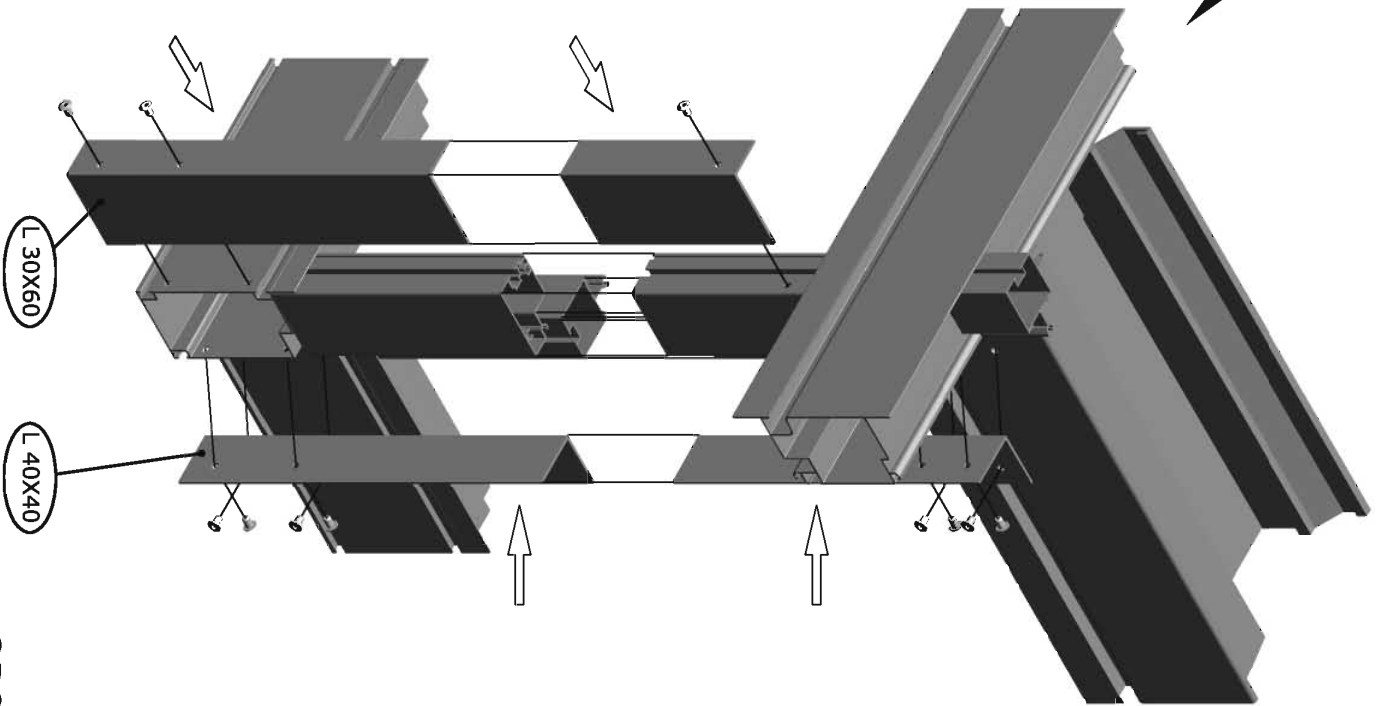
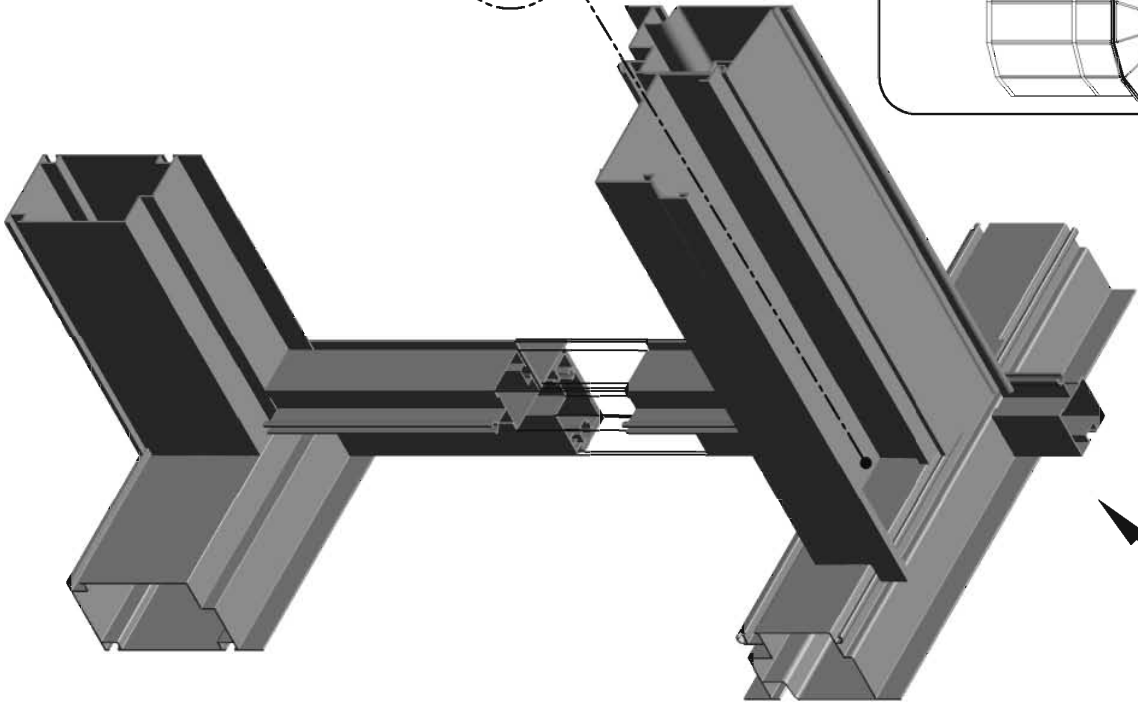
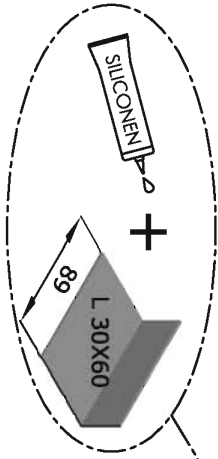
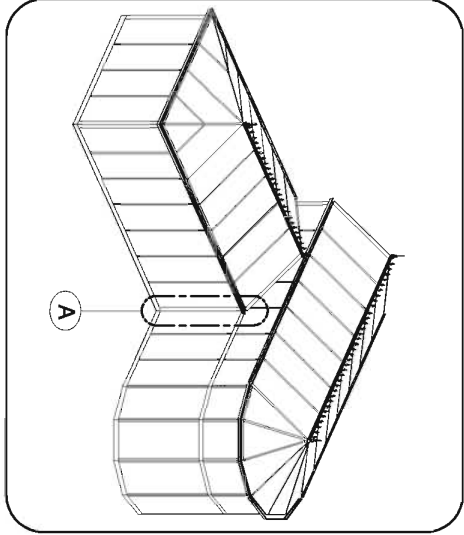

OR9

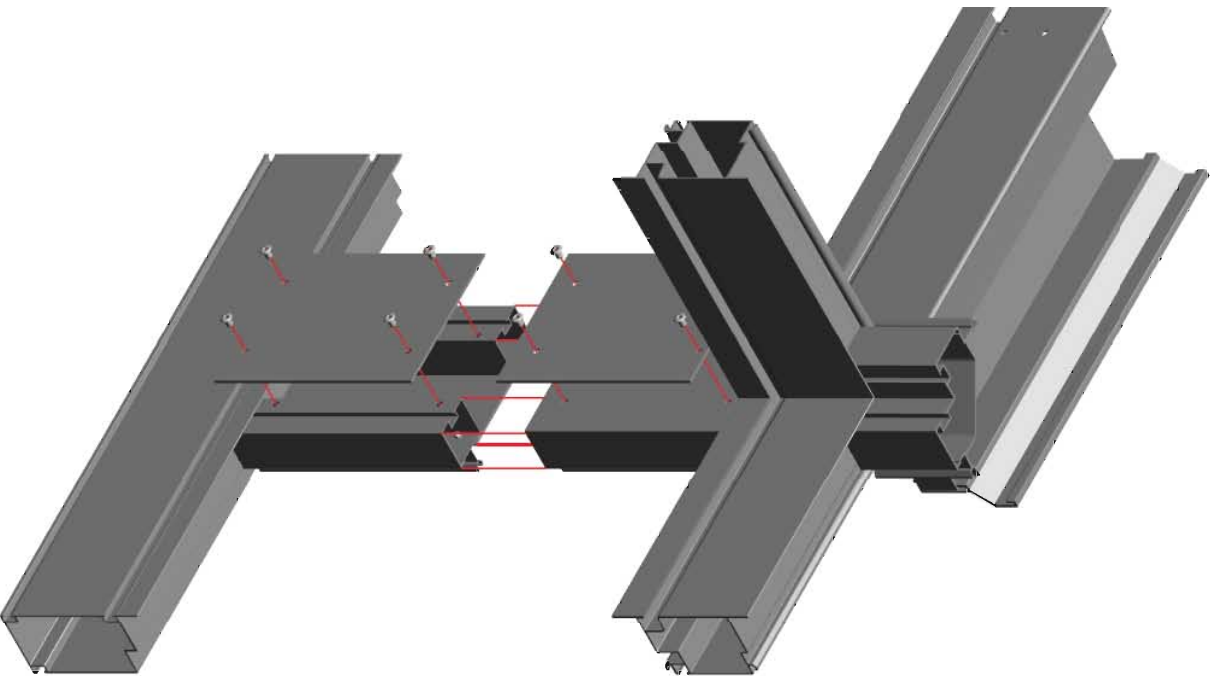
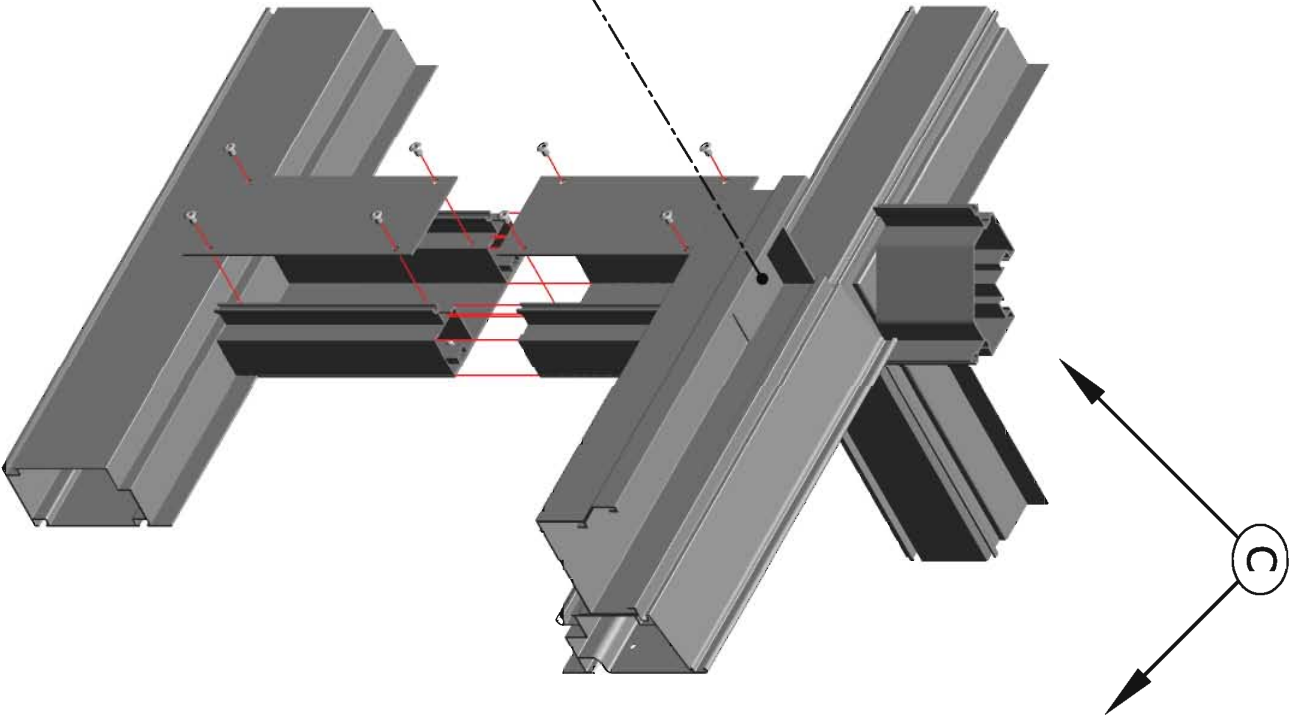
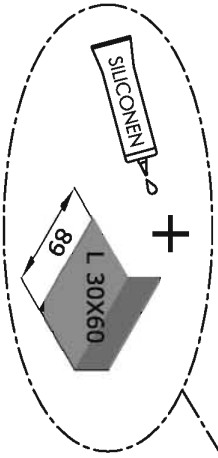
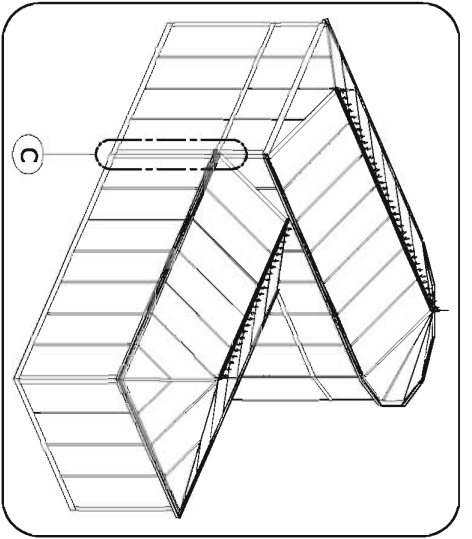

OR11

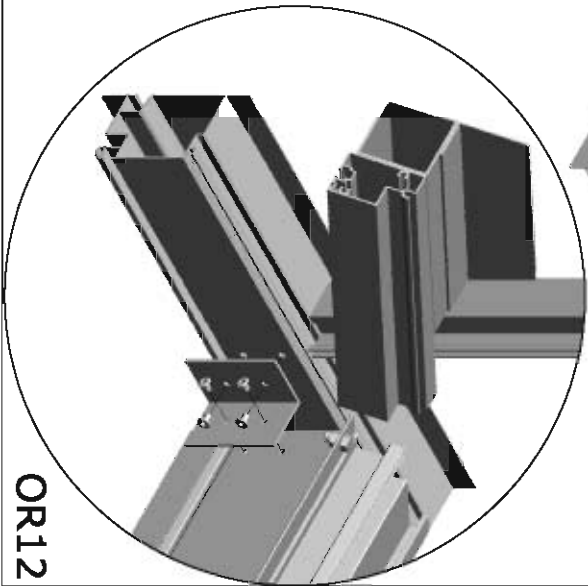
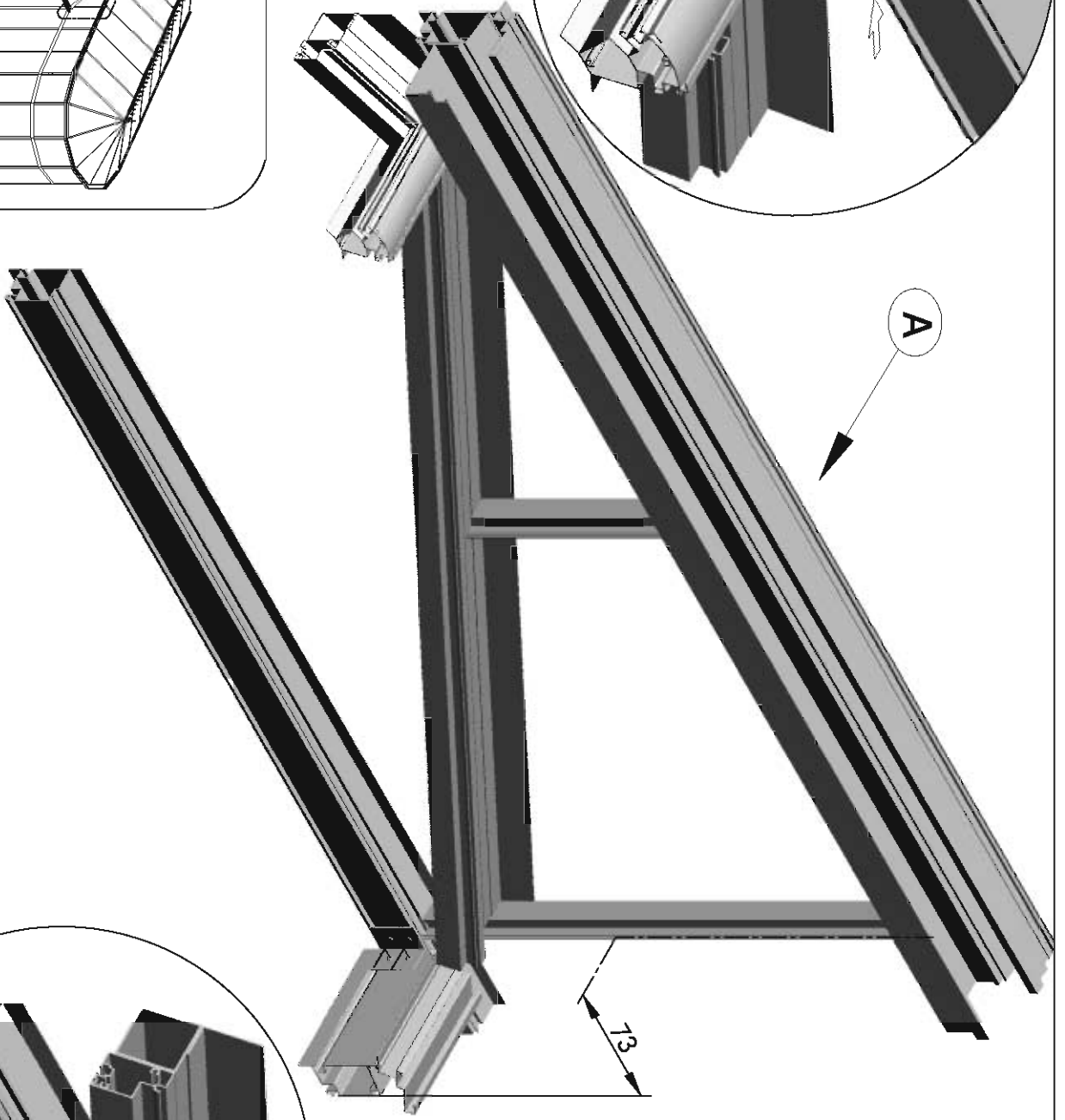
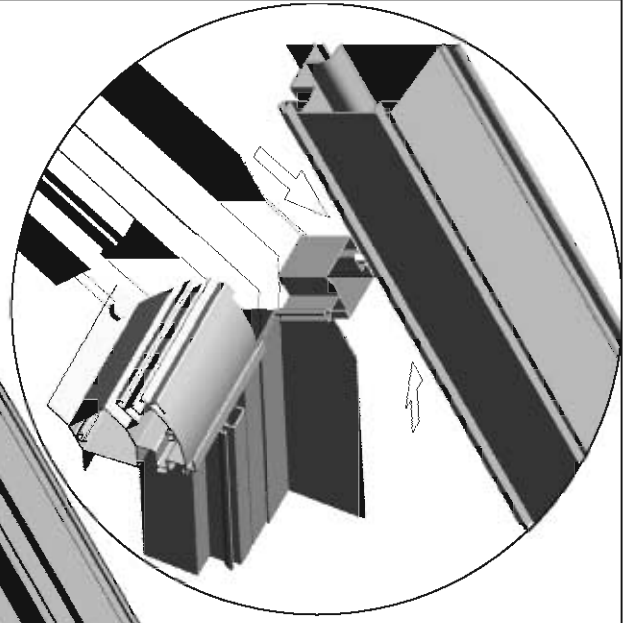
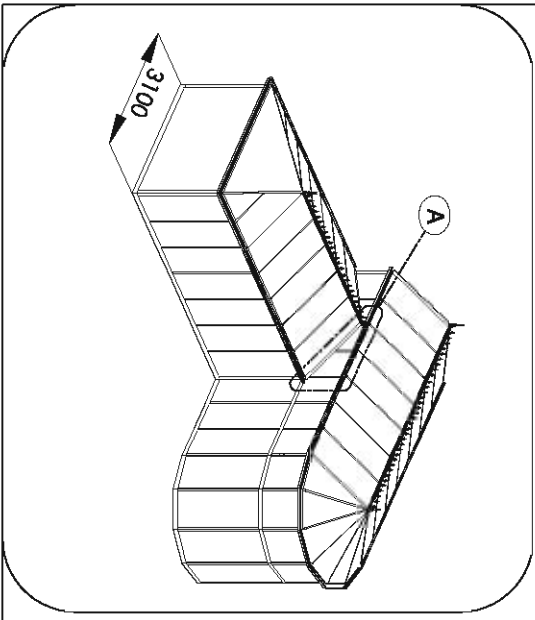

OR12

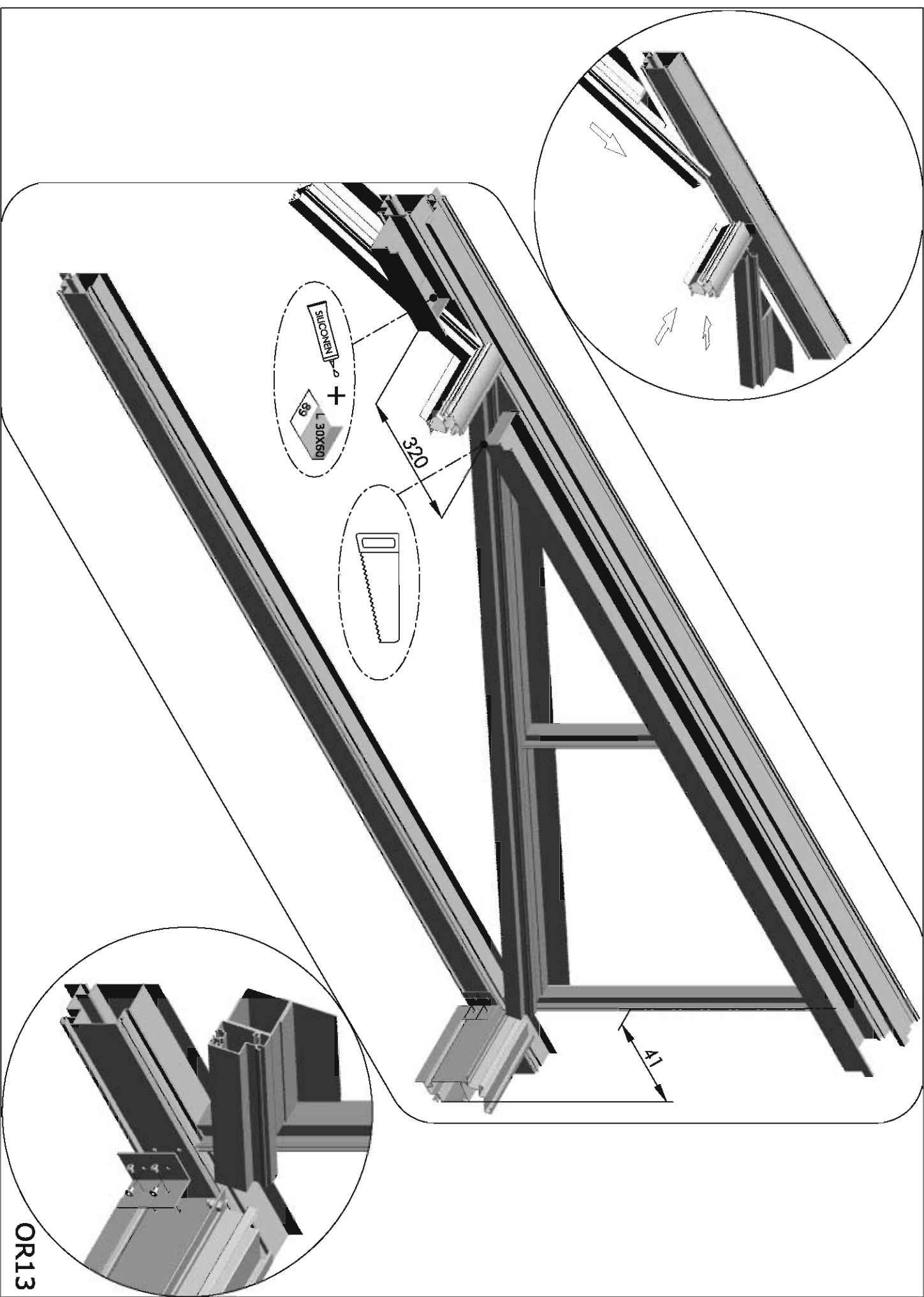

OR13

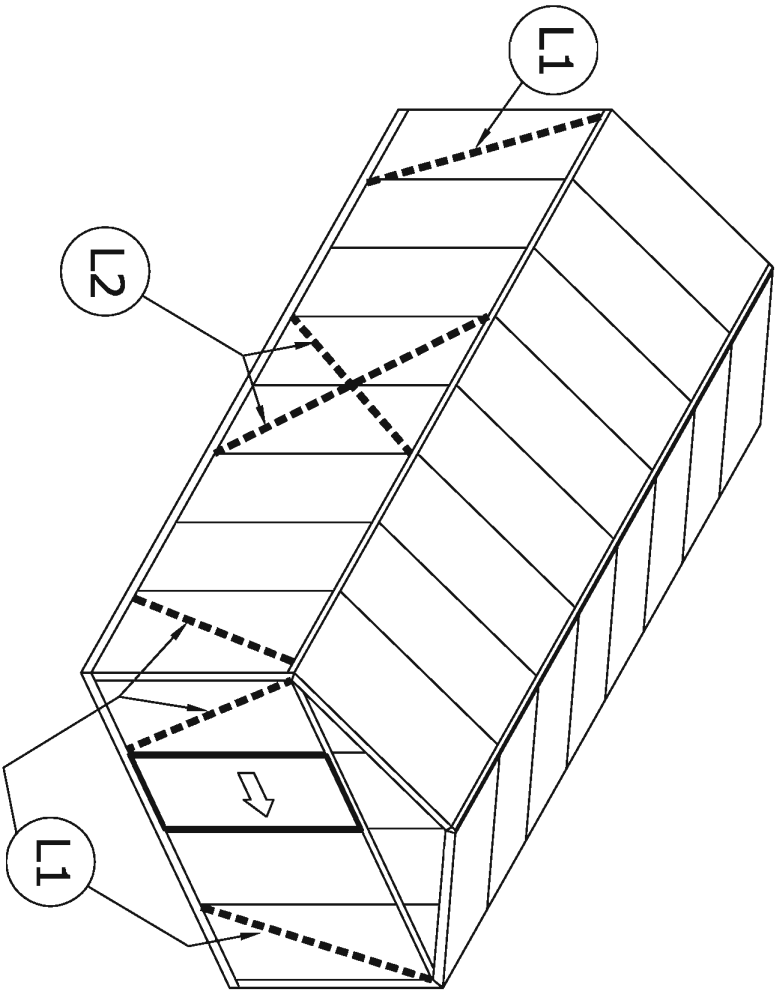

L1 = 1975mm
L2 = 2700mm

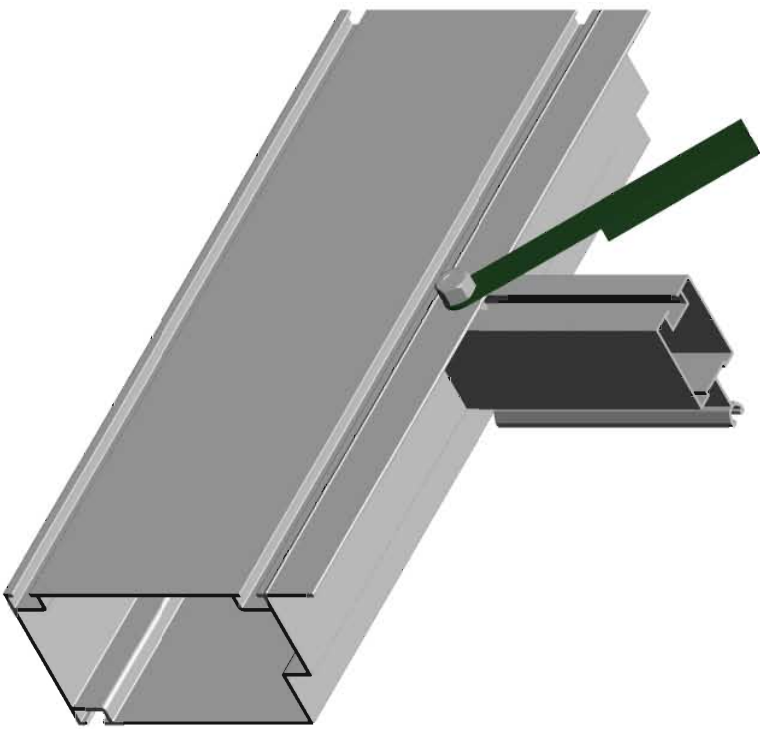

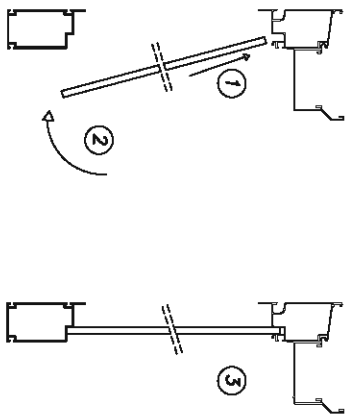
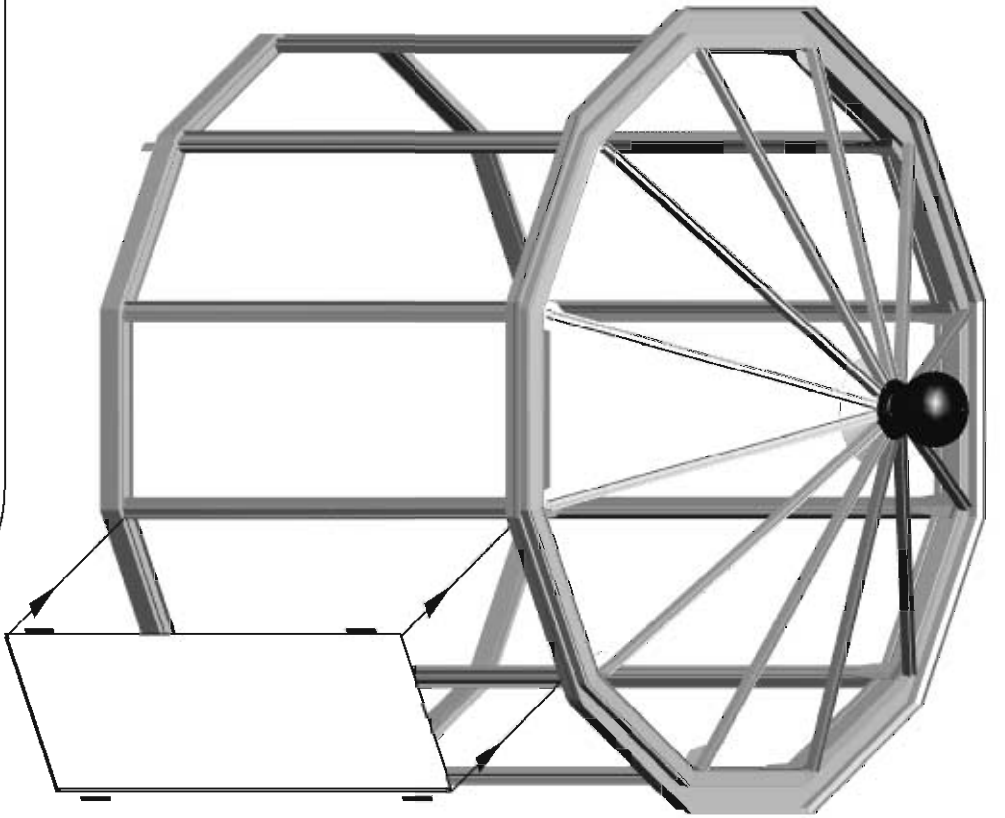

!!! K-glas: ● =Inside / Innersseite / Intérieur

SILICONEN

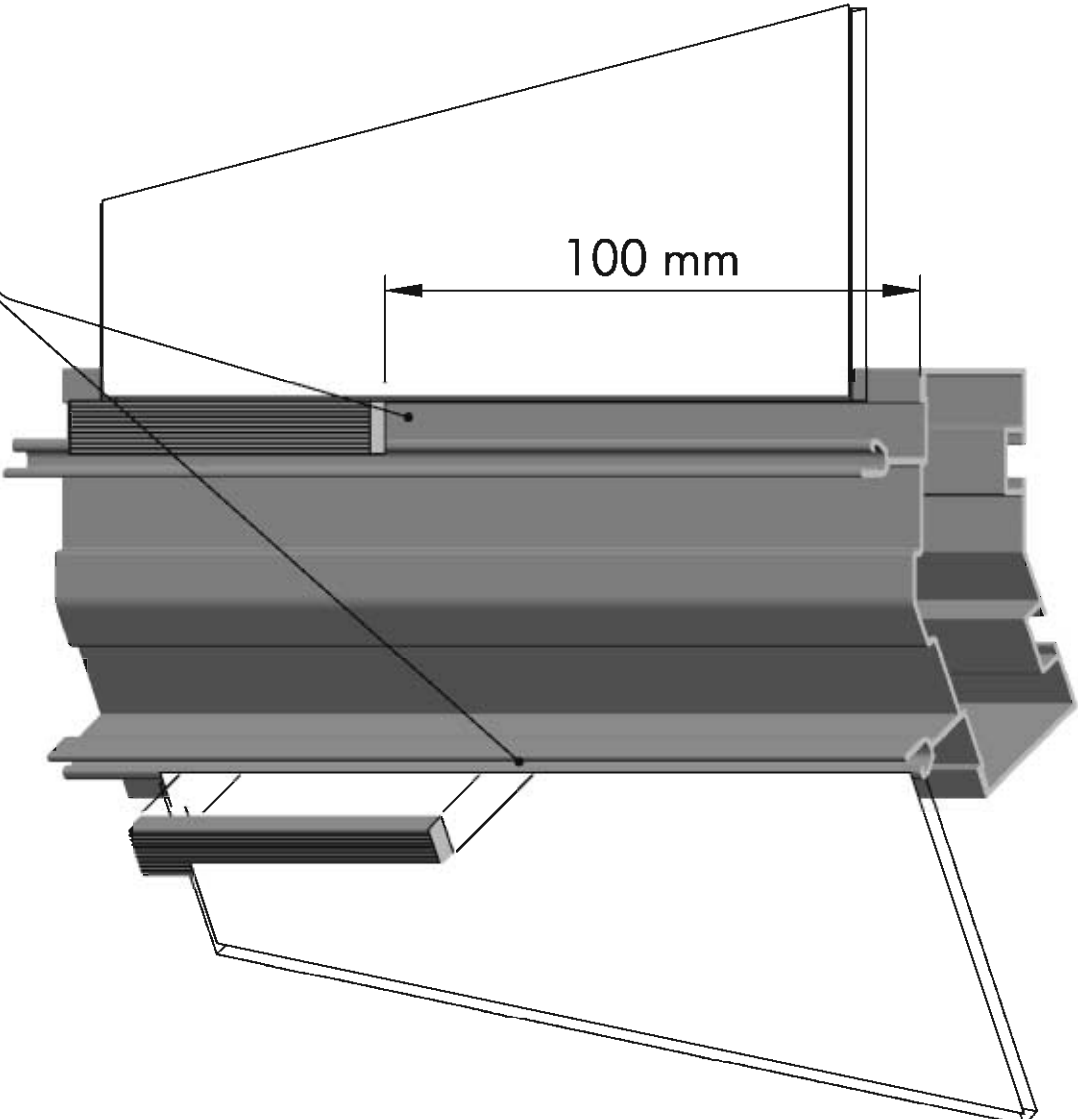

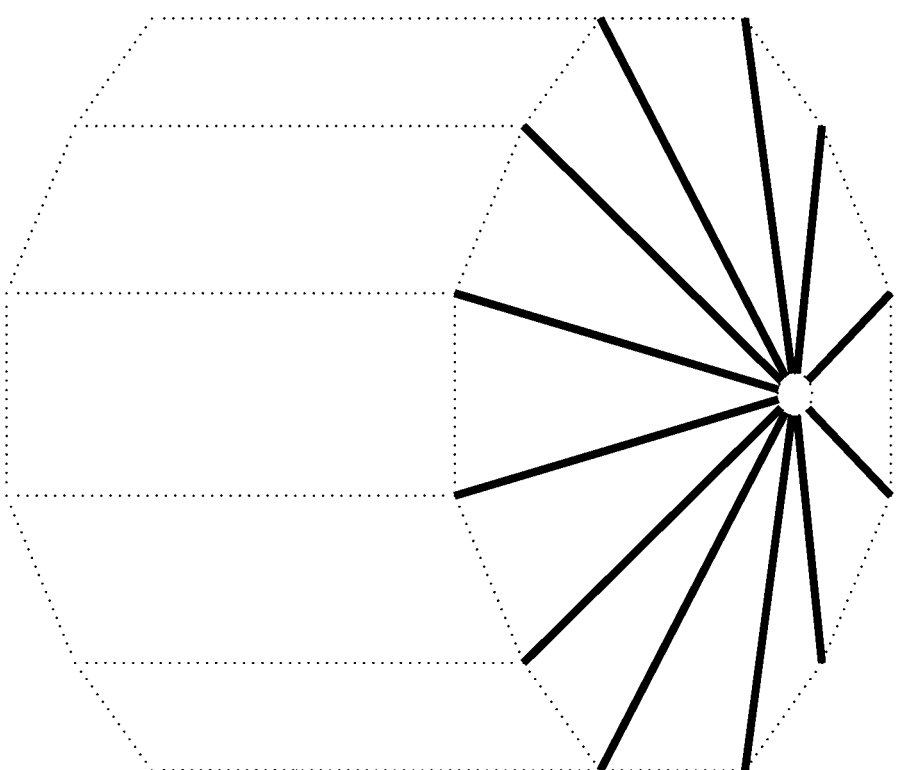
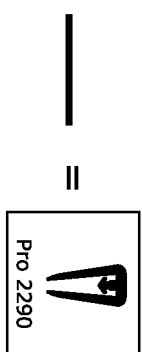
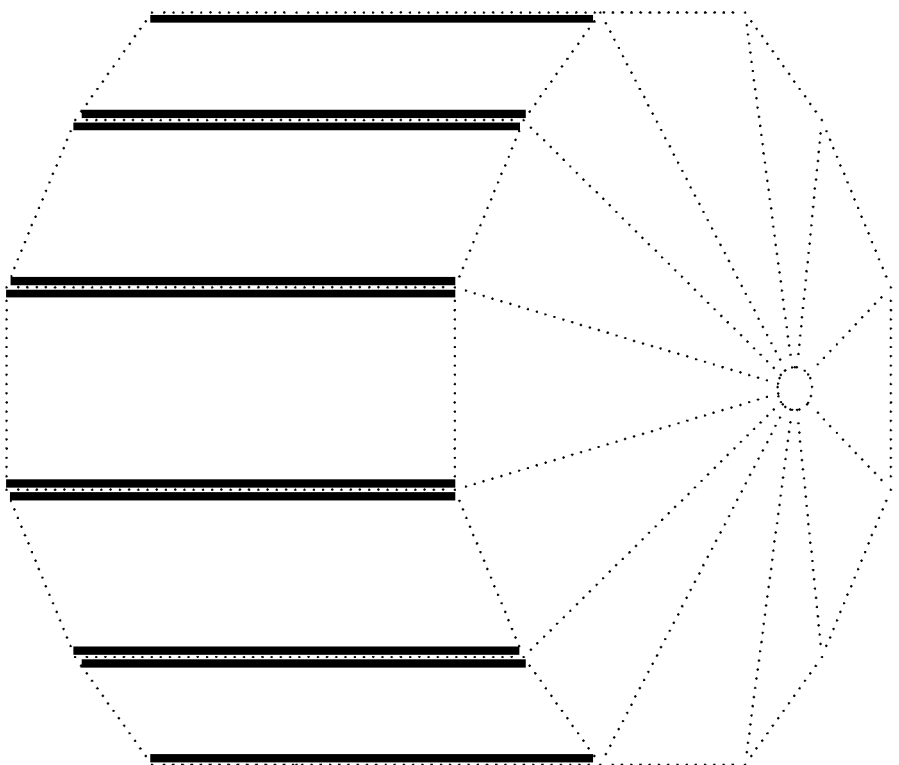
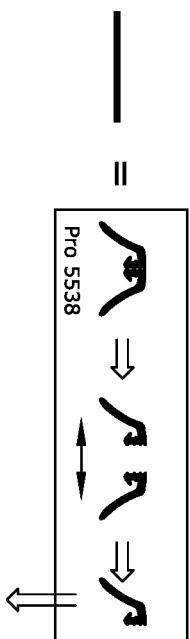

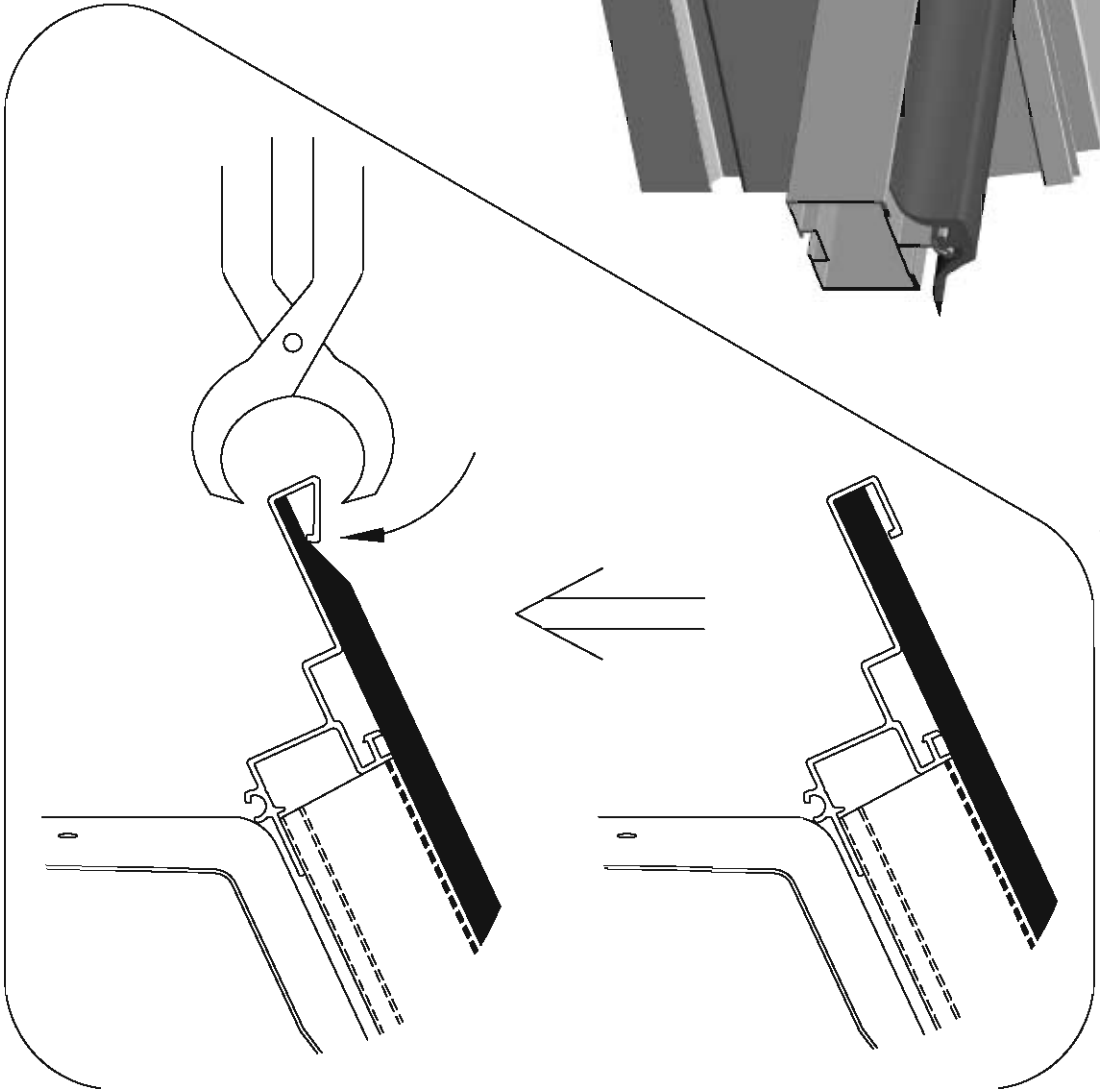
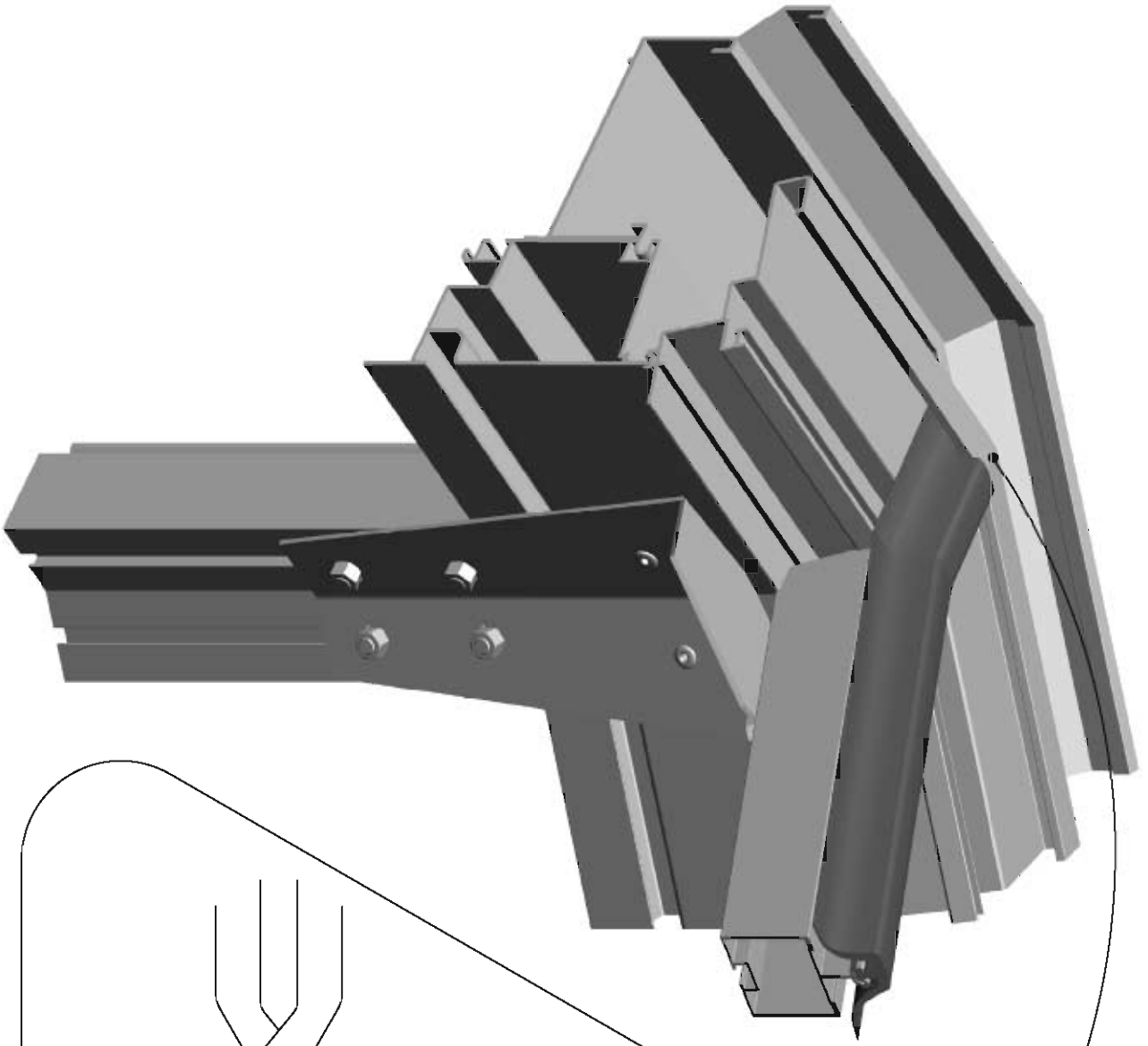

C11

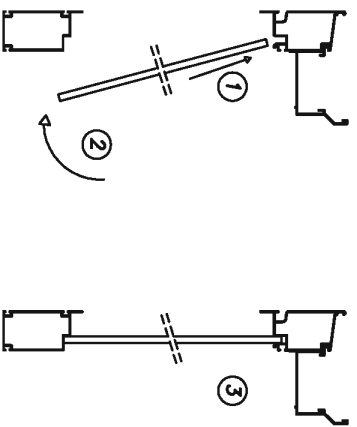
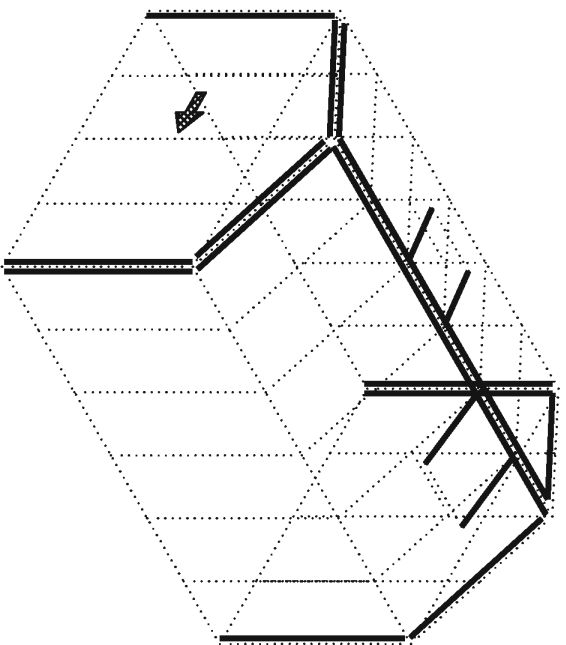
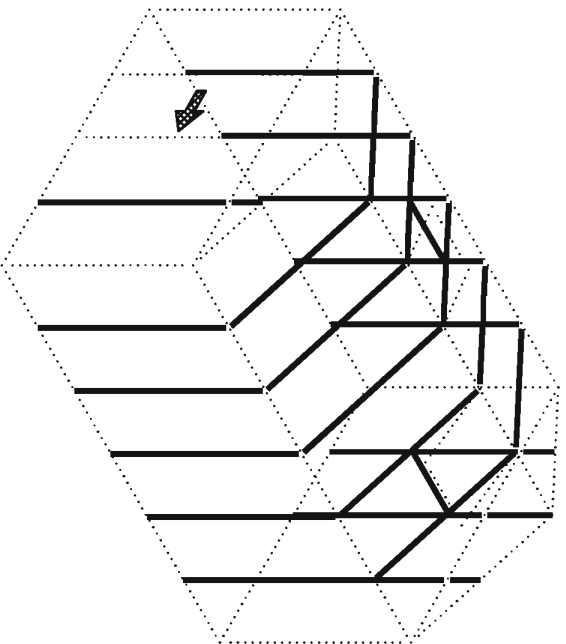
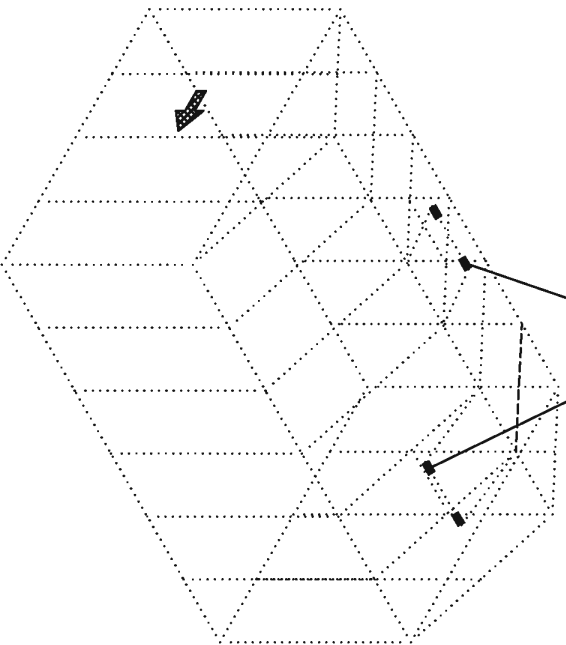
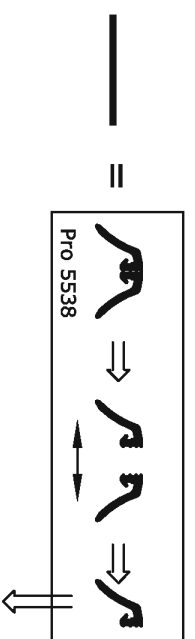
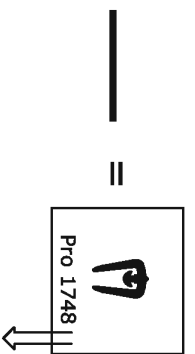
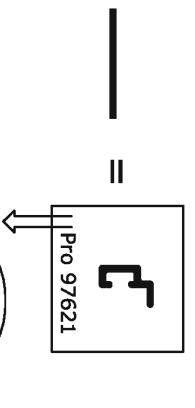

④

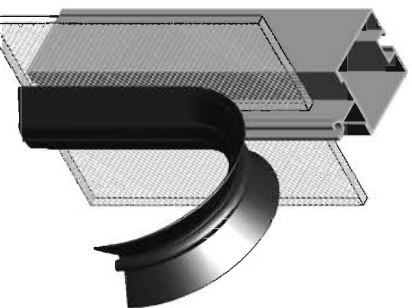

!!! K-glas: ● = Inside / Innerseite / Intérieur

G7

Zaibak-Bac de Culture-Kulturkübel-Seedbed-Blomsterbakke
Dyrkningskasse-Såbädd-Bancale da semina

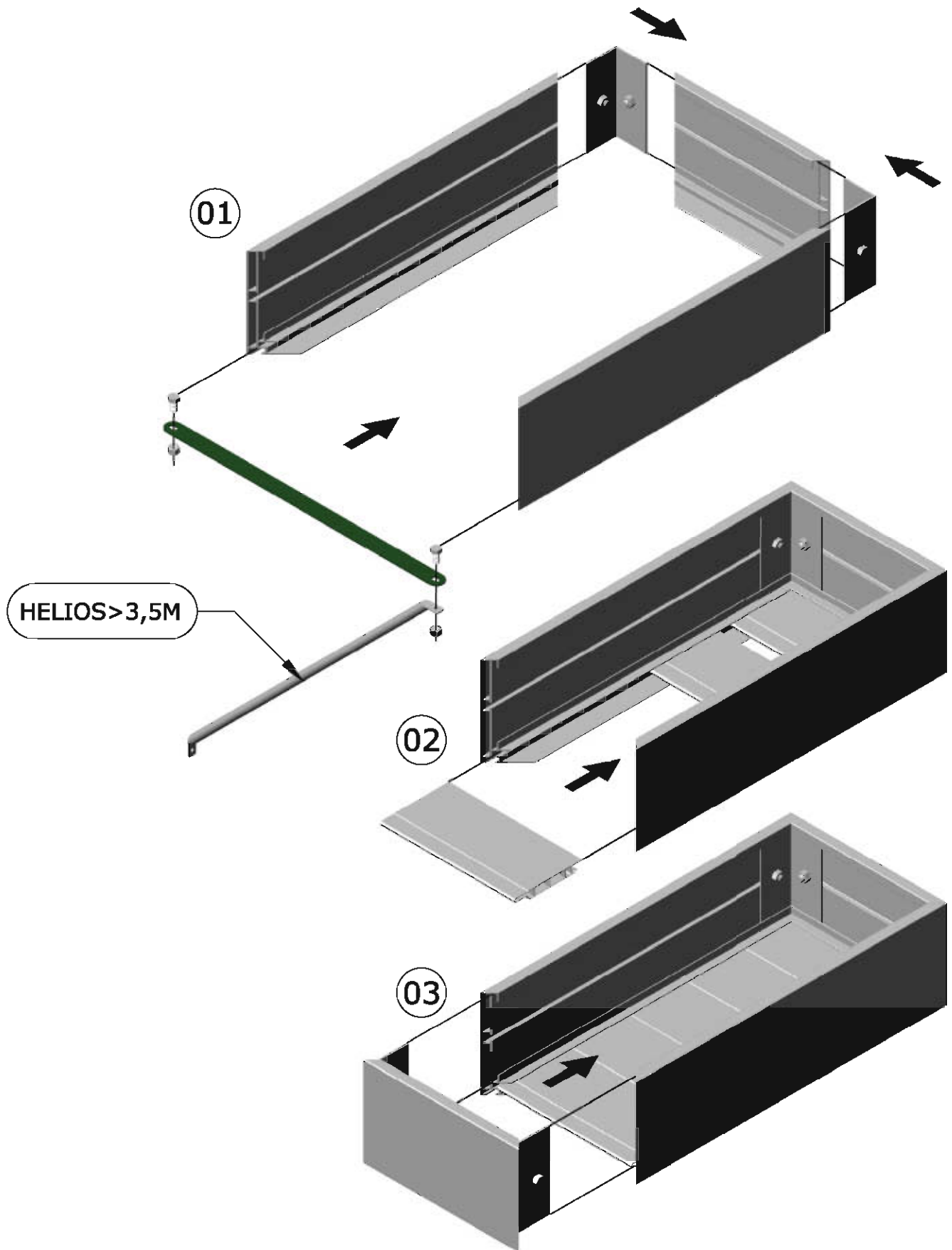

04

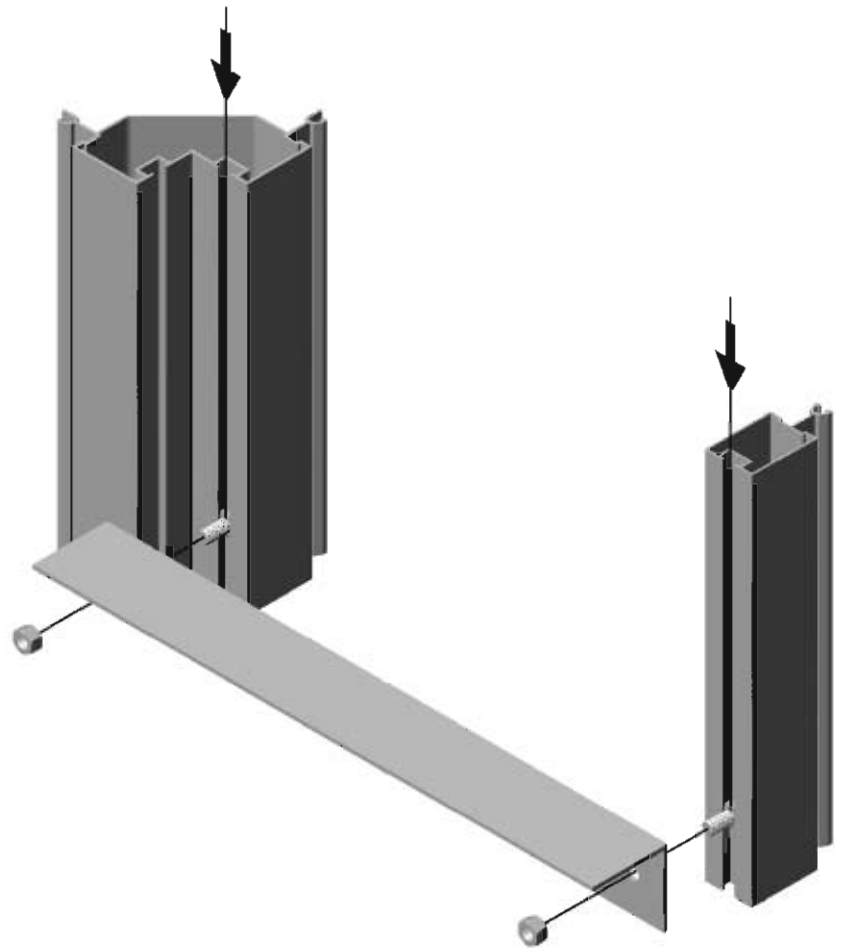

05

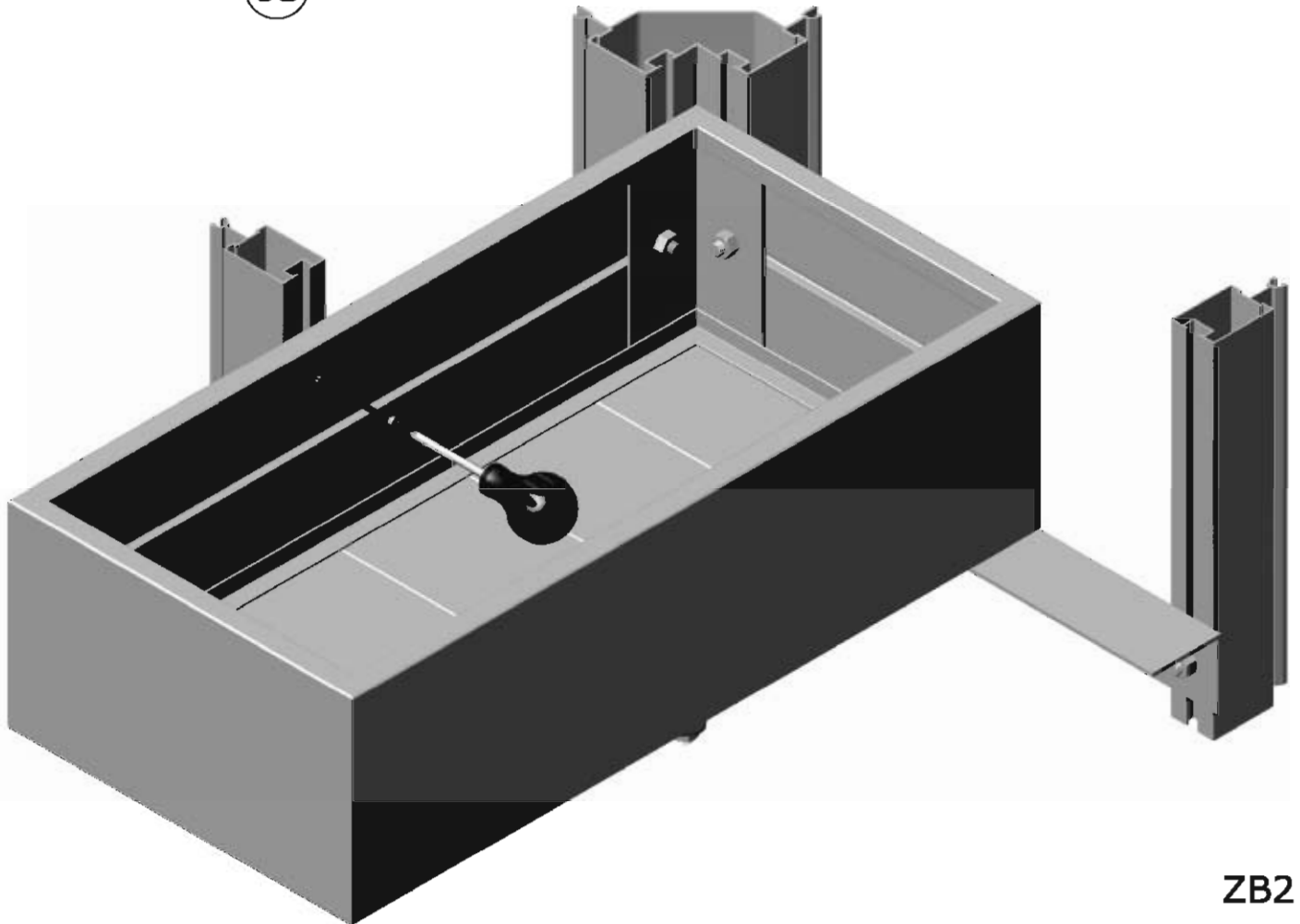

ZB2

Schap - Etapère - Abstellbord - Shelf - Hyide - Hyller - Hyllor - Ripiano di appoggio

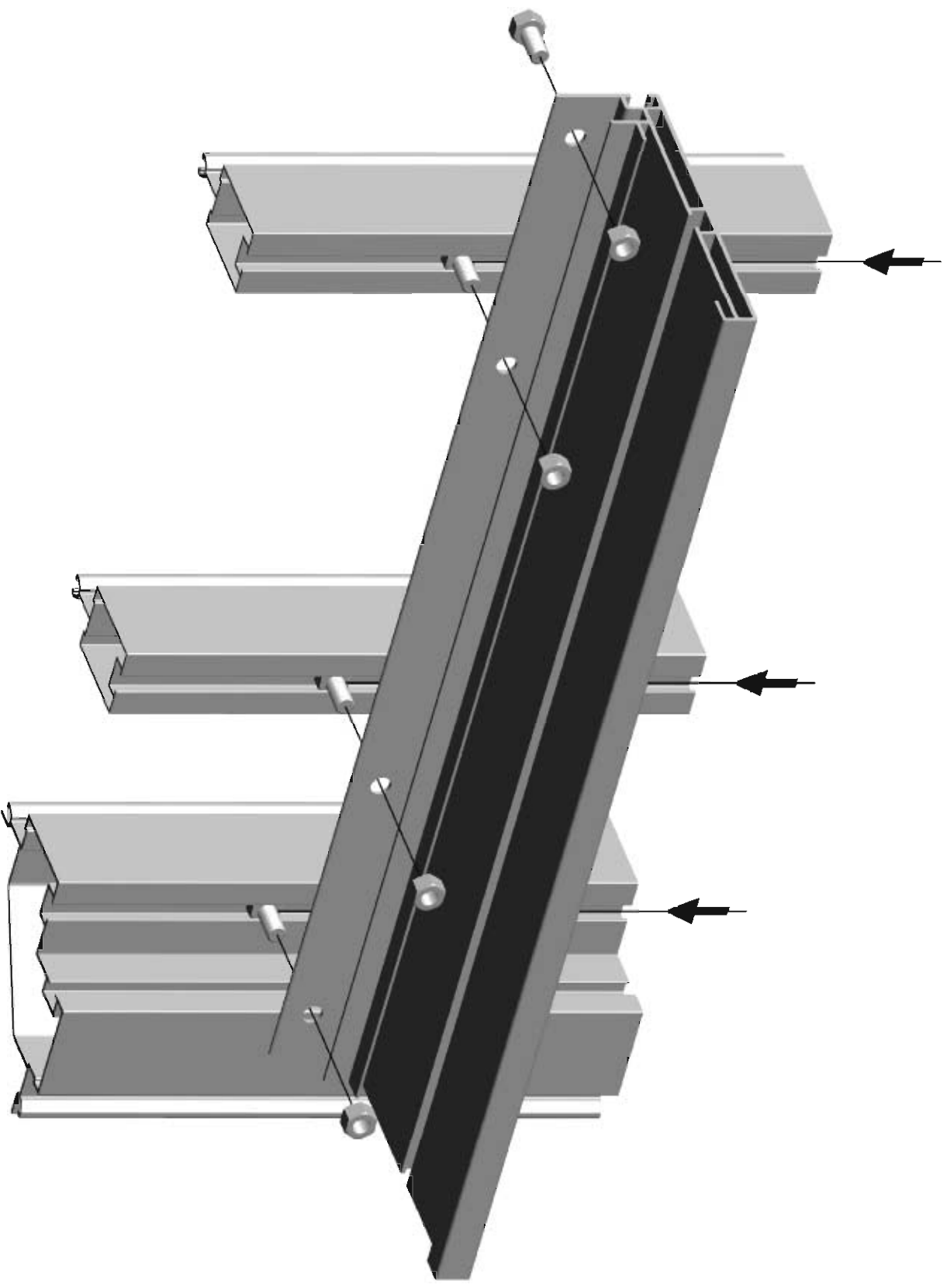





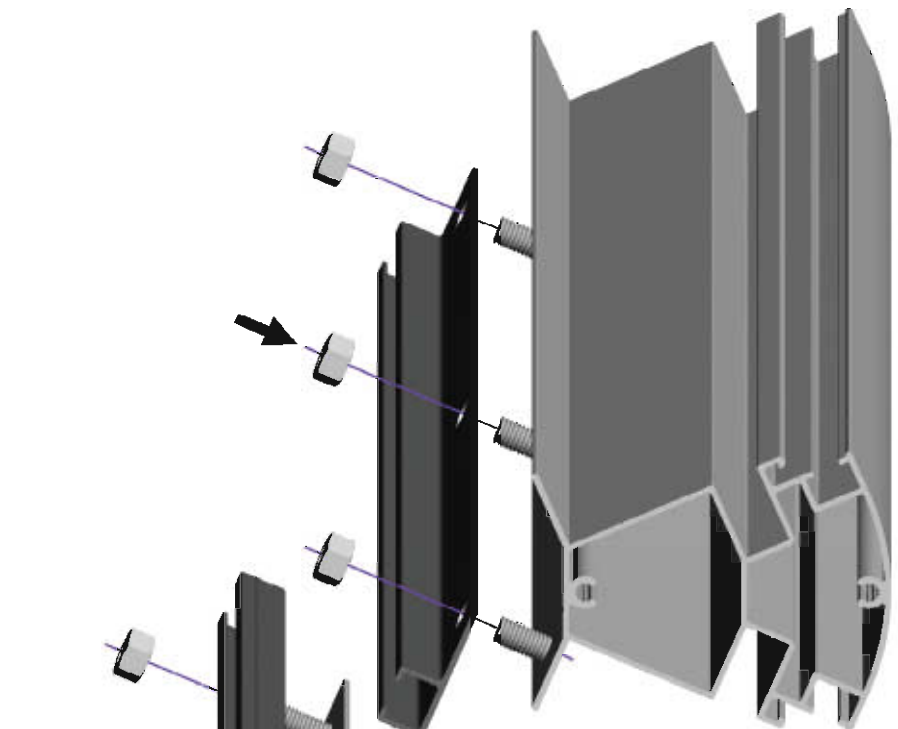

SC1

Schermdoek - Toile d' ombraie - Strahlenschutz - Sunscreen
 Solskærm-Solskjerm-Telo ombreggiante scorrevole

01



TYPE	H23 800	H34 800	H36 1000
	 1400	 1800	 2100
L=1150	2	2	2
L=900	2	2	2
	112	160	216
	4	4	4
	112	160	216
	4X L2970	4X L4440	4X L5470

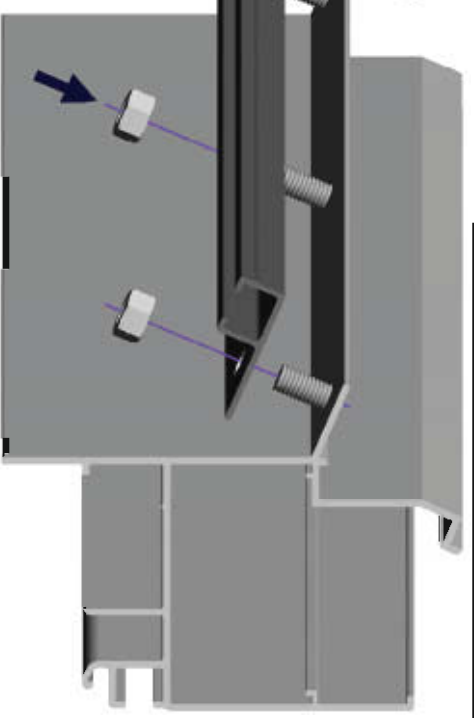

02



03



SD1

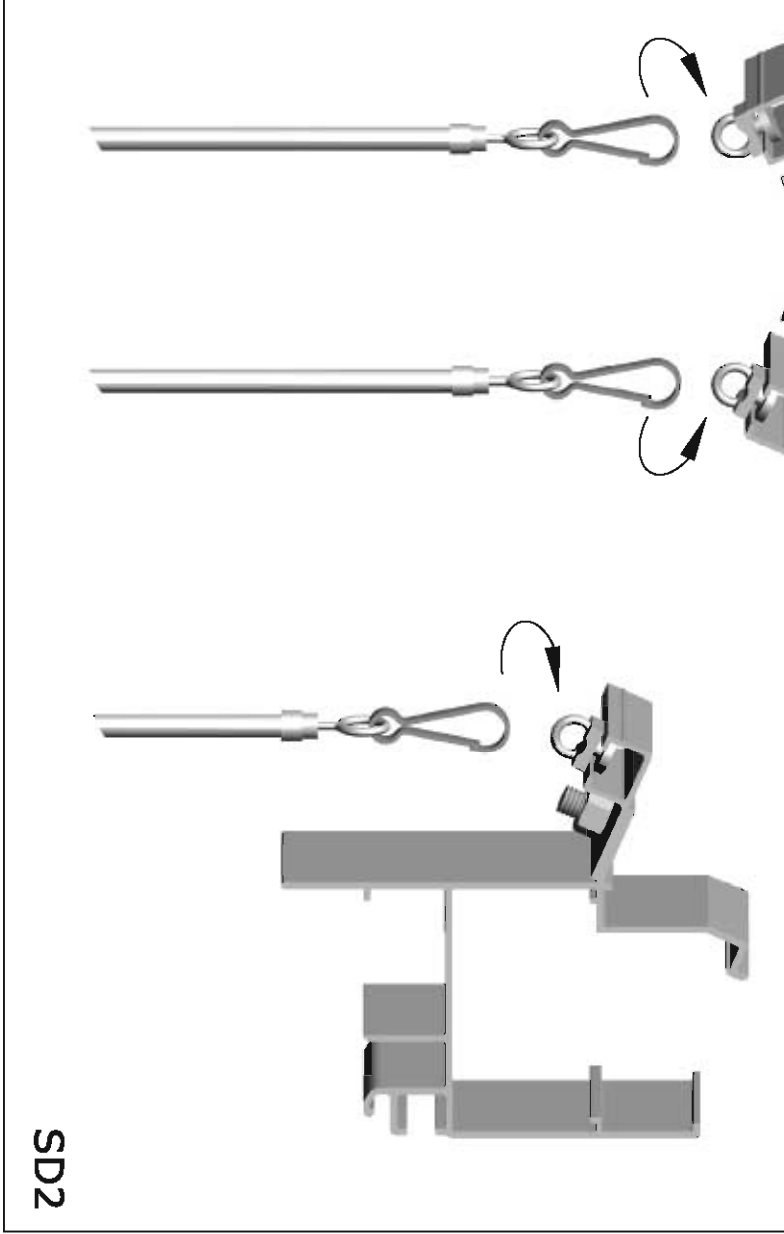
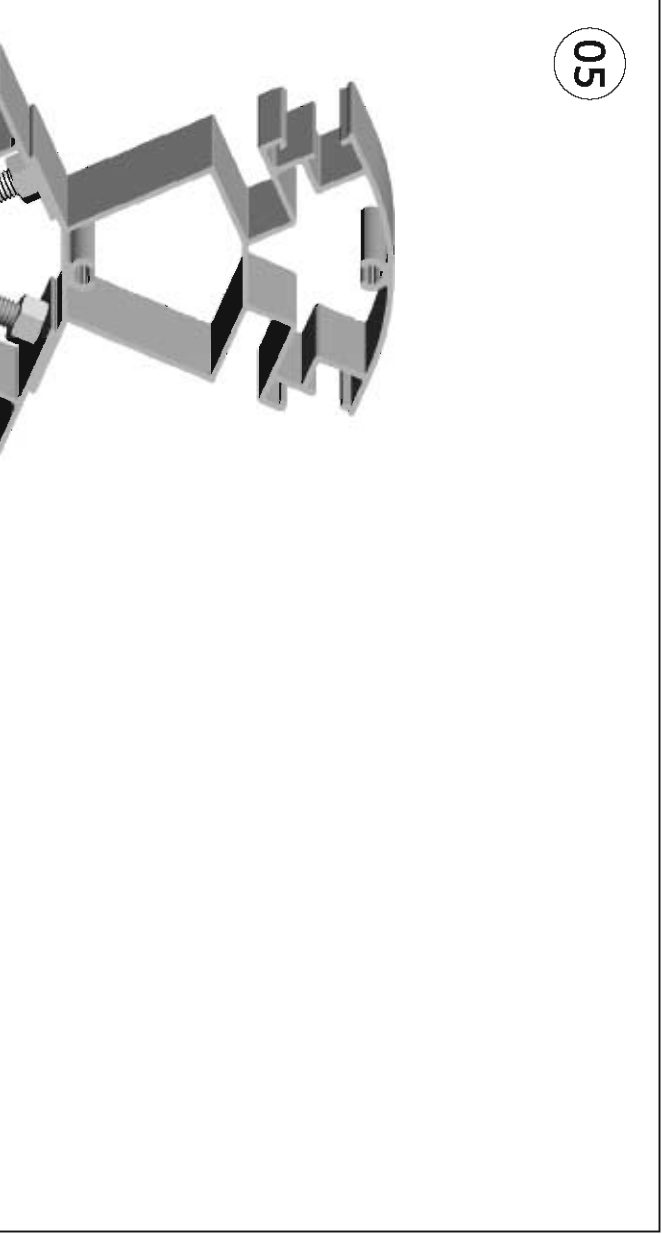
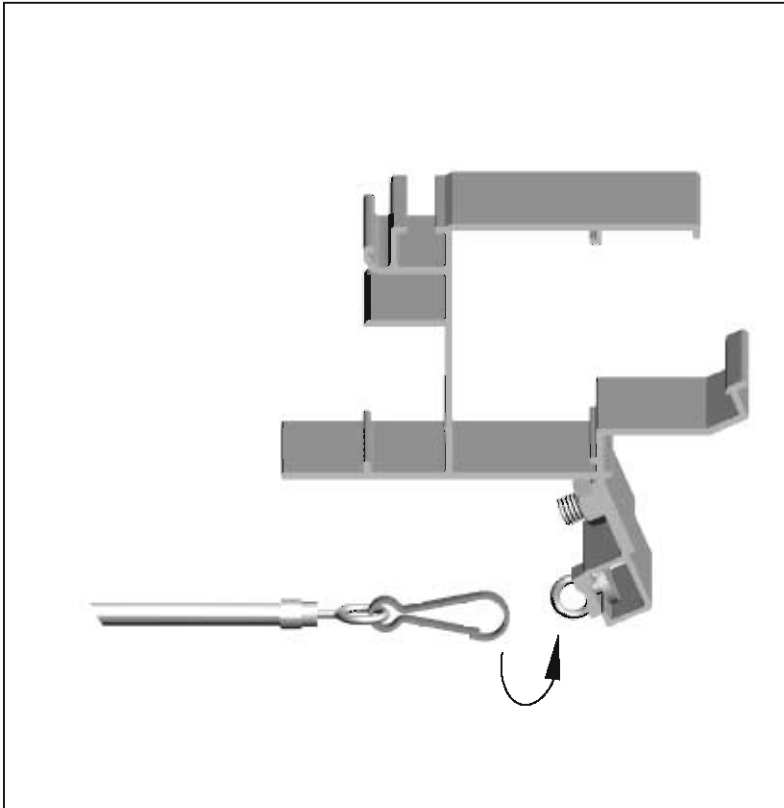
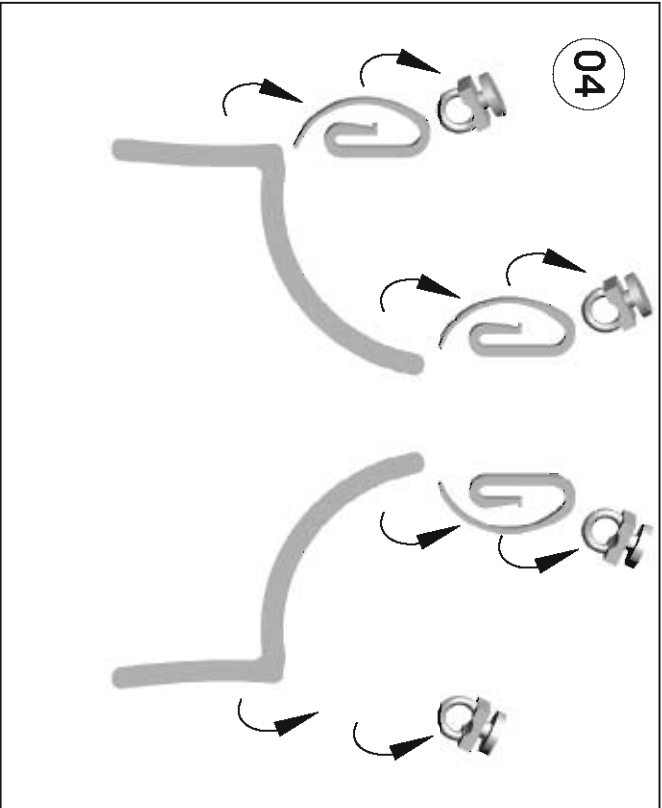

Schaduwnet-Filet d' ombrage-Sonnen Schütz-Shading Screen-Skyggegardin-
Rete ombreggiante fissa

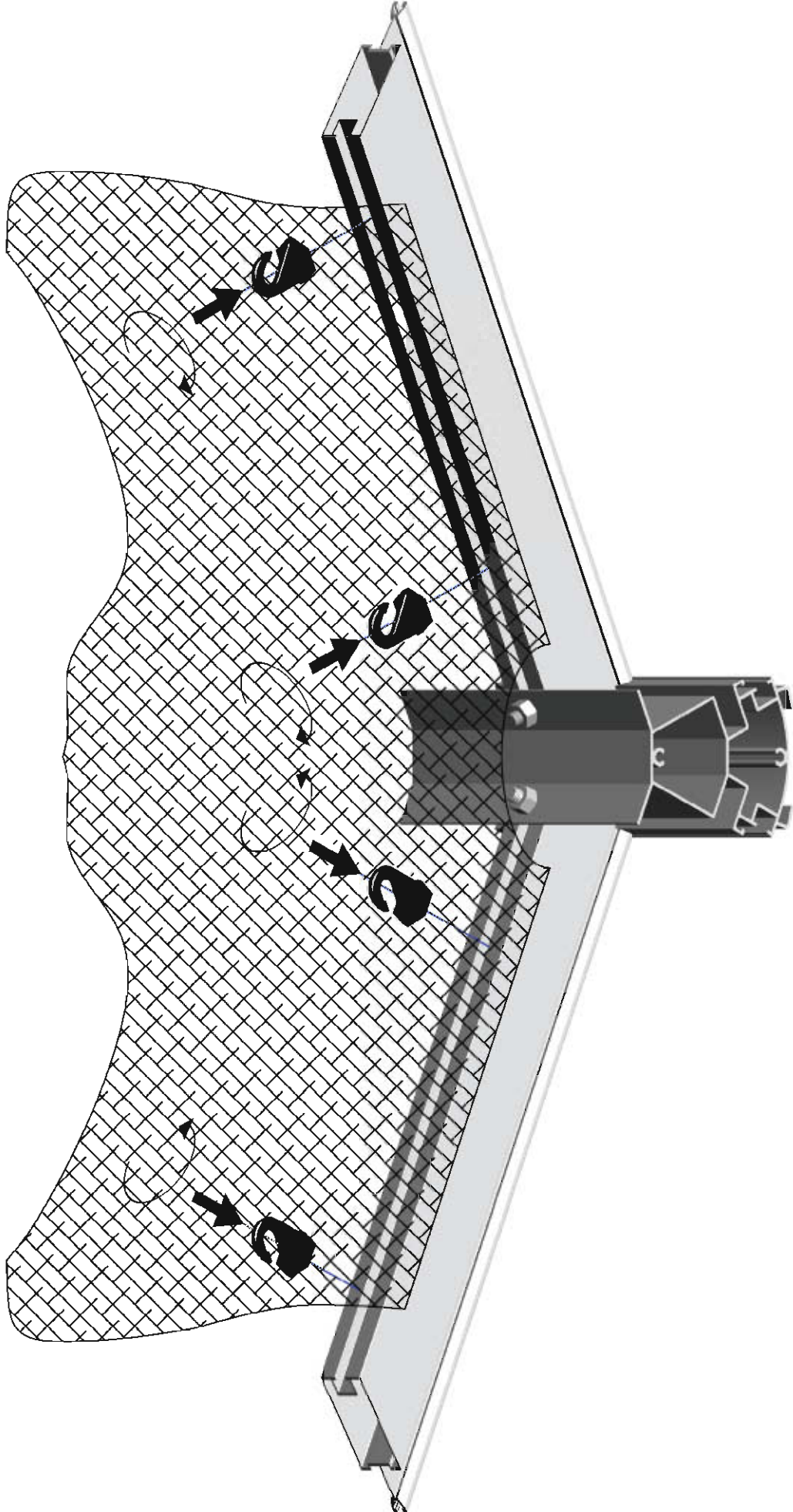

Vliegenraam-Fenêtre moustiquaire-Fliegengitter für Fenster
Fly screen window-Fluënet til vindue-

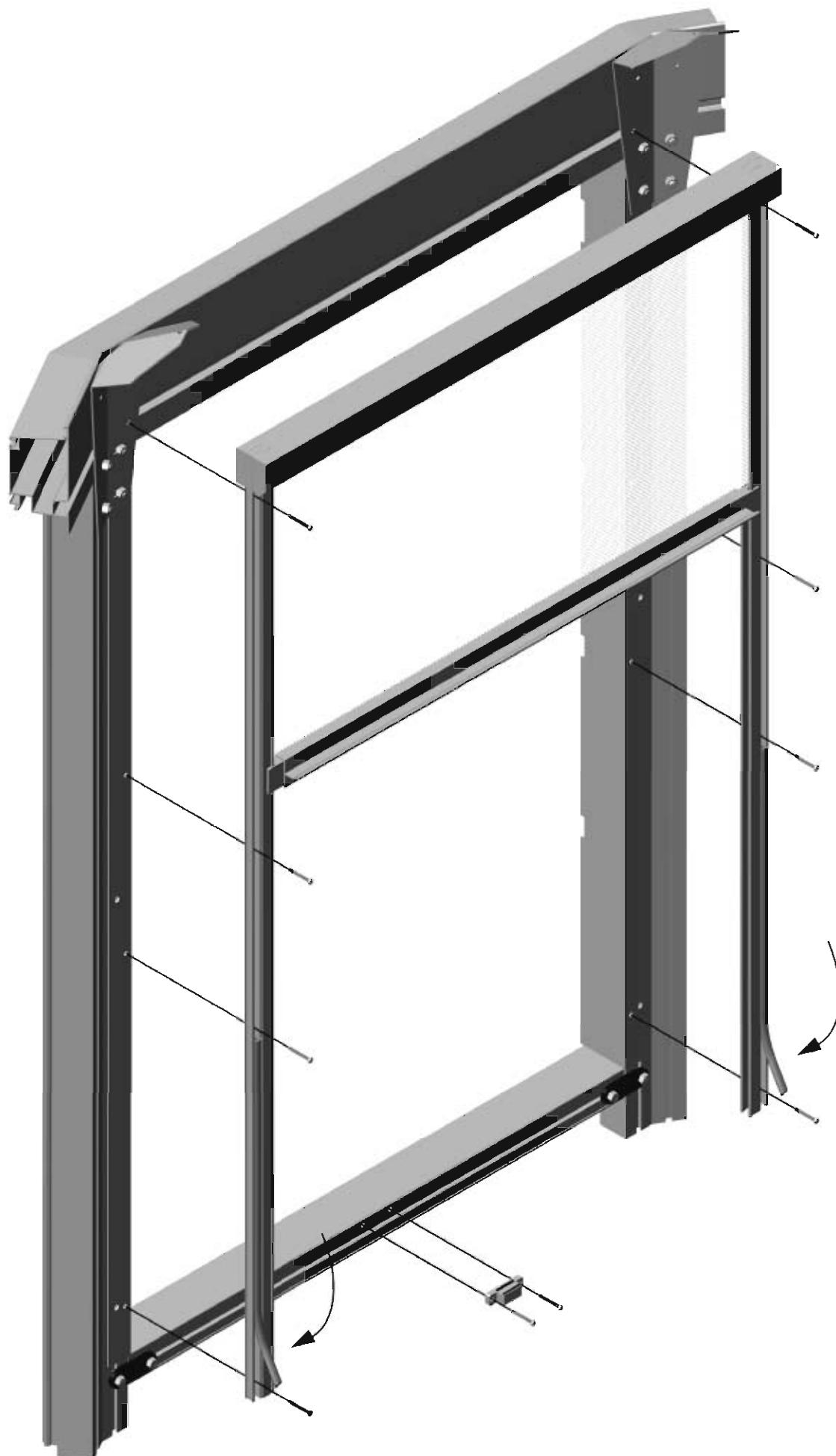

Vliegendeur-Porte moustiquaire-Fliegengitter für Schiebetür
Fly screen sliding door-Fluenet til skydedør-

